

1200Ø SLAB BASE

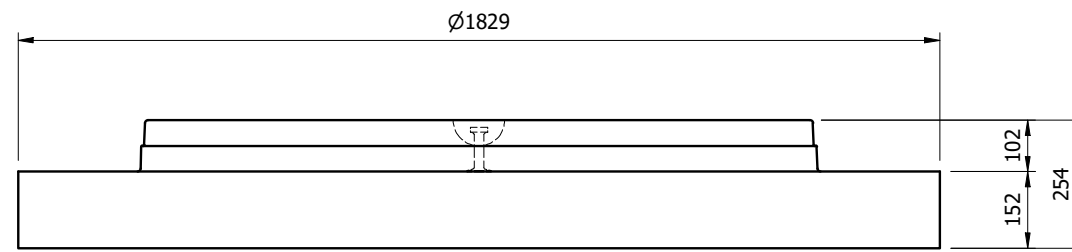

1200Ø OVERSIZED SLAB BASE

**NOTES:**

- ALL DIMENSIONS ARE IN MILLIMETERS UNLESS OTHERWISE NOTED
- ALL ELEVATIONS ARE IN METERS ABOVE SEA LEVEL

APPROXIMATE WEIGHTS		
PIECE	lb	kg
1200	2,127	967
1200 (OS)	2,870	1,305

# STANDARD TEMPLATE

**PROPRIETARY AND CONFIDENTIAL:**

THE INFORMATION CONTAINED IN THIS DRAWING IS THE SOLE PROPERTY OF PRECON MANUFACTURING LTD. ANY REPRODUCTION IN PART OR AS A WHOLE WITHOUT THE WRITTEN PERMISSION OF PRECON MANUFACTURING LTD. IS PROHIBITED.



© Precon Manufacturing Ltd. www.precon.ca 1-800-661-8020

CONTRACTOR:

PROJECT:

LOCATION:

DESCRIPTION:  
**Ø1200 SLAB BASES**

STRUCTURE NAME:

DRAWN:	CHECKED:
DATE CREATED: 08/26/2020	REQUIRED:
LAST REVISION:	SCALE: 1:15
PROJECT NUMBER:	DRAWING:

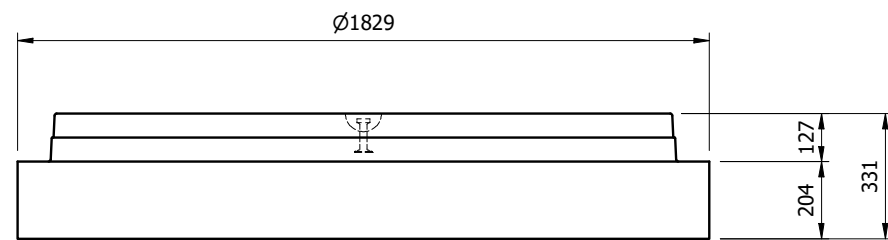
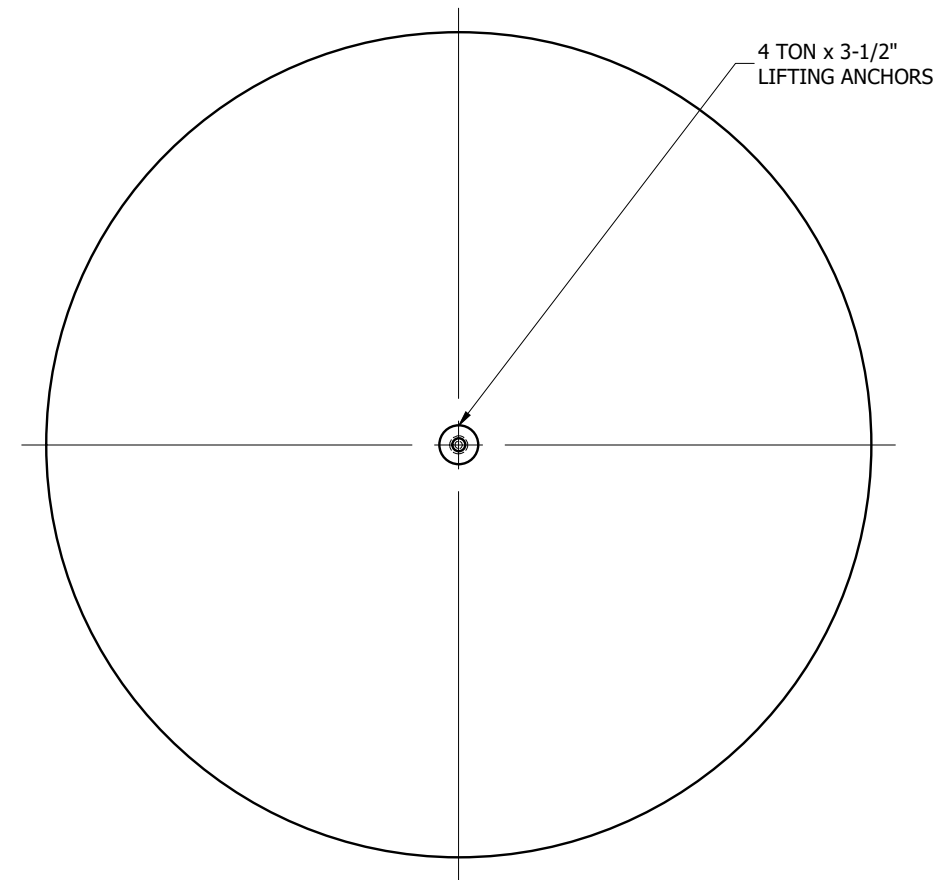
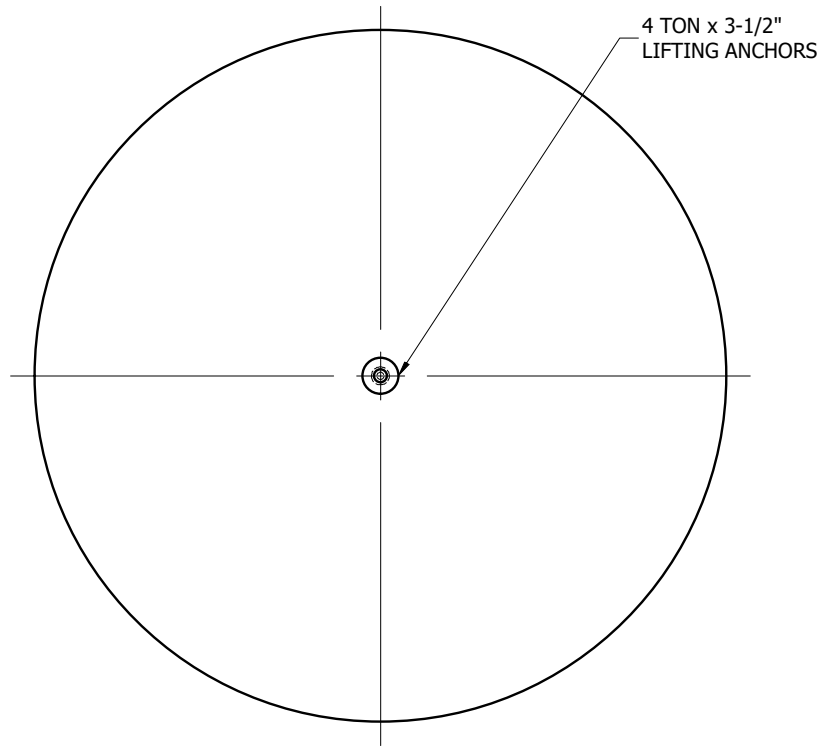

1500Ø SLAB BASE

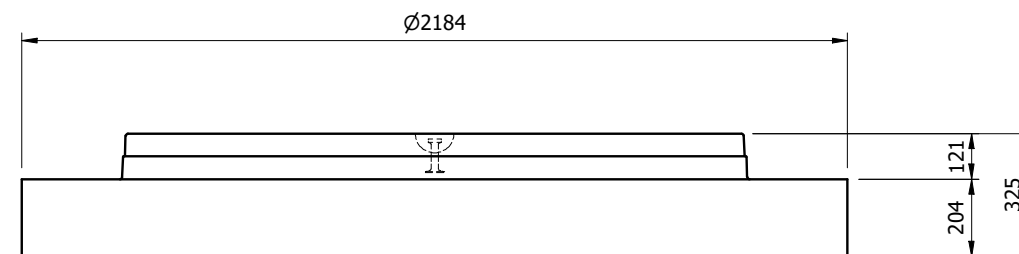

1500Ø OVERSIZED SLAB BASE

**NOTES:**

- ALL DIMENSIONS ARE IN MILLIMETERS UNLESS OTHERWISE NOTED
- ALL ELEVATIONS ARE IN METERS ABOVE SEA LEVEL

APPROXIMATE WEIGHTS		
PIECE	lb	kg
1500	4,268	1,940
1500 (OS)	5,409	2,459

# STANDARD TEMPLATE

**PROPRIETARY AND CONFIDENTIAL:**

THE INFORMATION CONTAINED IN THIS DRAWING IS THE SOLE PROPERTY OF PRECON MANUFACTURING LTD. ANY REPRODUCTION IN PART OR AS A WHOLE WITHOUT THE WRITTEN PERMISSION OF PRECON MANUFACTURING LTD. IS PROHIBITED.



© Precon Manufacturing Ltd. www.precon.ca 1-800-661-8020

CONTRACTOR:

PROJECT:

LOCATION:

DESCRIPTION:  
**Ø1500 SLAB BASE**

STRUCTURE NAME:

DRAWN:	CHECKED:
DATE CREATED: 08/26/2020	REQUIRED:
LAST REVISION:	SCALE: 1:20
PROJECT NUMBER:	DRAWING:

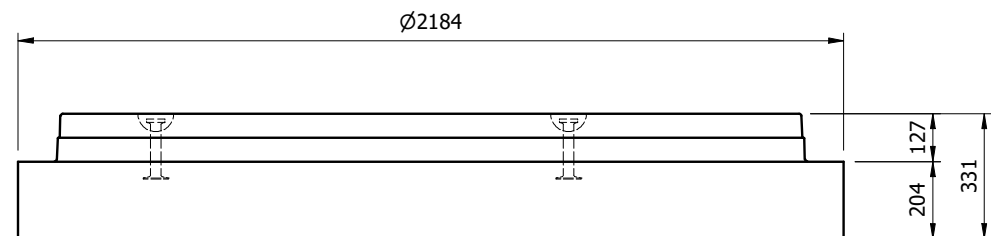
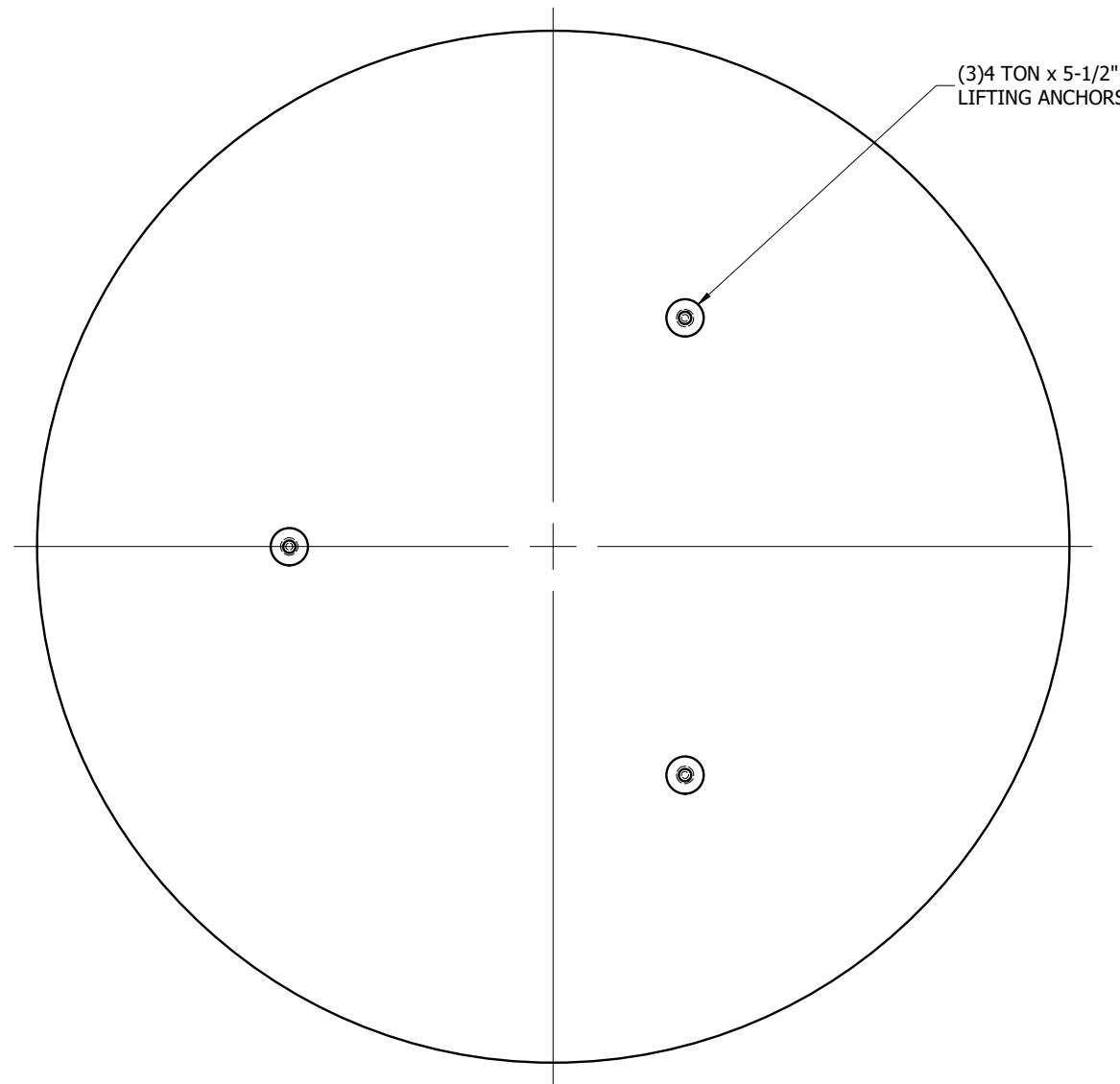
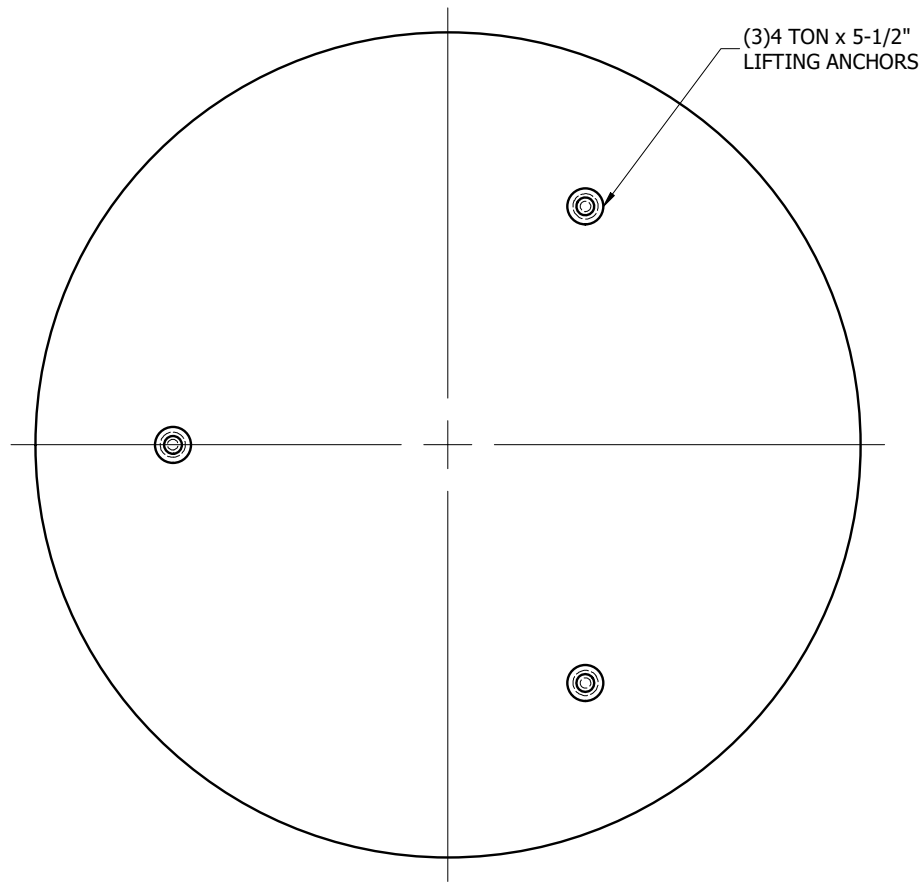

1800Ø MONOBASE

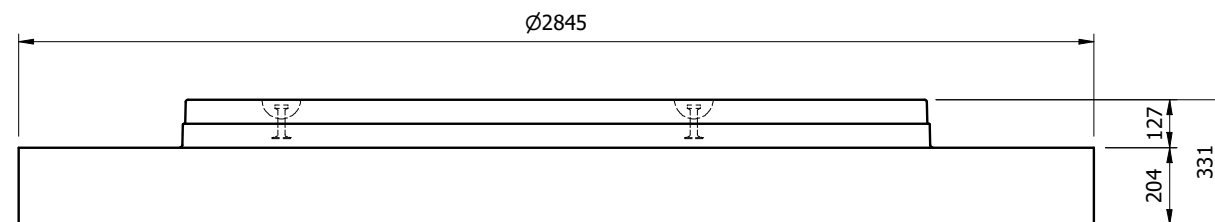

1800Ø OVERSIZED SLAB BASE

**NOTES:**

- ALL DIMENSIONS ARE IN MILLIMETERS UNLESS OTHERWISE NOTED
- ALL ELEVATIONS ARE IN METERS ABOVE SEA LEVEL

APPROXIMATE WEIGHTS		
PIECE	lb	kg
1800	6,098	2,772
1800 (OS)	8,918	4,054

# STANDARD TEMPLATE

**PROPRIETARY AND CONFIDENTIAL:**

THE INFORMATION CONTAINED IN THIS DRAWING IS THE SOLE PROPERTY OF PRECON MANUFACTURING LTD. ANY REPRODUCTION IN PART OR AS A WHOLE WITHOUT THE WRITTEN PERMISSION OF PRECON MANUFACTURING LTD. IS PROHIBITED.



© Precon Manufacturing Ltd. www.precon.ca 1-800-661-8020

CONTRACTOR:

PROJECT:

LOCATION:

DESCRIPTION:  
**Ø1800 SLAB BASES**

STRUCTURE NAME:

DRAWN: CHECKED:

DATE CREATED: 08/26/2020 REQUIRED:

LAST REVISION: SCALE: 1:20

PROJECT NUMBER: DRAWING:

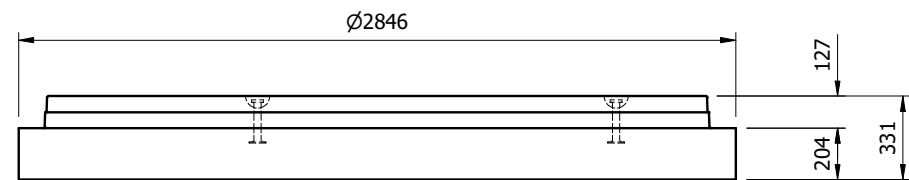
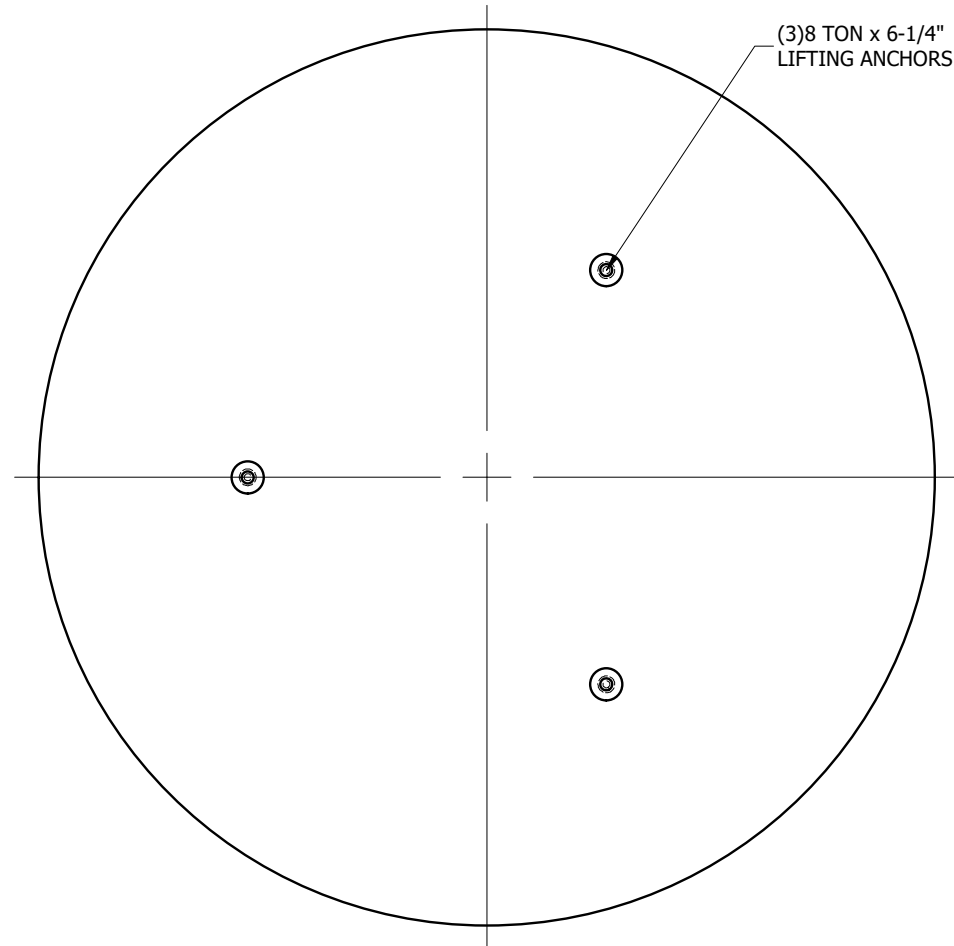
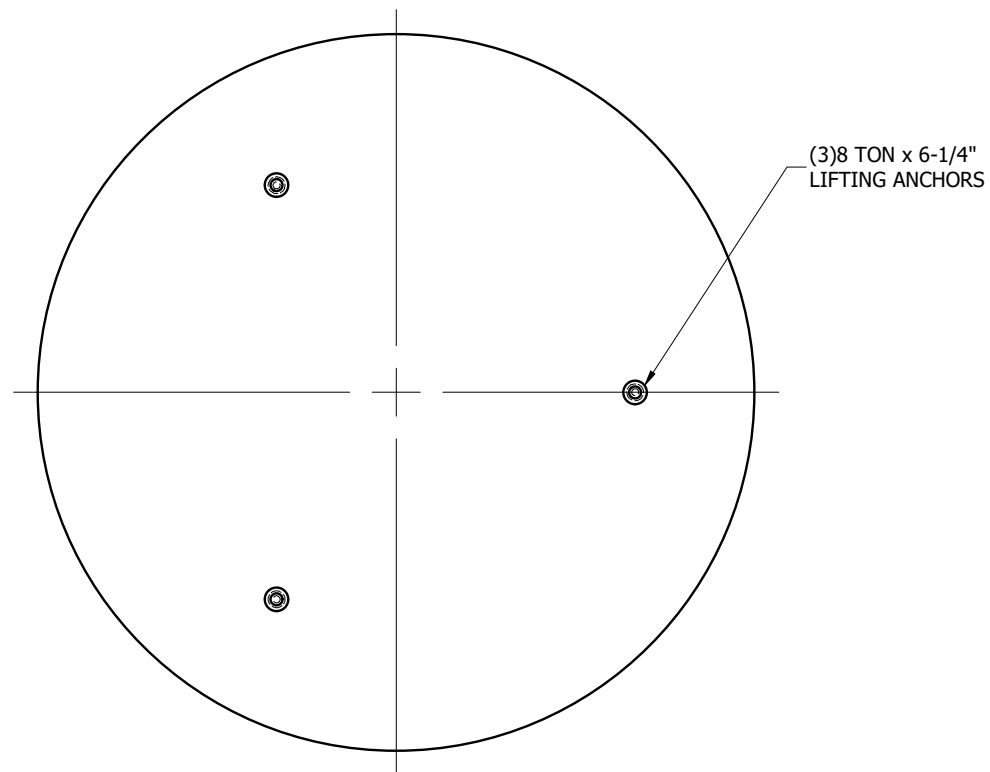

2400Ø SLAB BASE

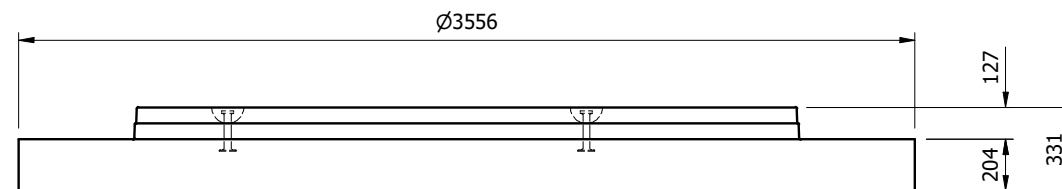

2400Ø OVERSIZED SLAB BASE

**NOTES:**

- ALL DIMENSIONS ARE IN MILLIMETERS UNLESS OTHERWISE NOTED
- ALL ELEVATIONS ARE IN METERS ABOVE SEA LEVEL

APPROXIMATE WEIGHTS		
PIECE	lb	kg
2400	10,538	4,790
2400 (OS)	14,382	6,537

# STANDARD TEMPLATE

**PROPRIETARY AND CONFIDENTIAL:**

THE INFORMATION CONTAINED IN THIS DRAWING IS THE SOLE PROPERTY OF PRECON MANUFACTURING LTD. ANY REPRODUCTION IN PART OR AS A WHOLE WITHOUT THE WRITTEN PERMISSION OF PRECON MANUFACTURING LTD. IS PROHIBITED.



© Precon Manufacturing Ltd. www.precon.ca 1-800-661-8020

CONTRACTOR:

PROJECT:

LOCATION:

DESCRIPTION:  
**Ø2400 SLAB BASES**

STRUCTURE NAME:

DRAWN:	CHECKED:
DATE CREATED: 08/26/2020	REQUIRED:
LAST REVISION:	SCALE: 1:30
PROJECT NUMBER:	DRAWING:

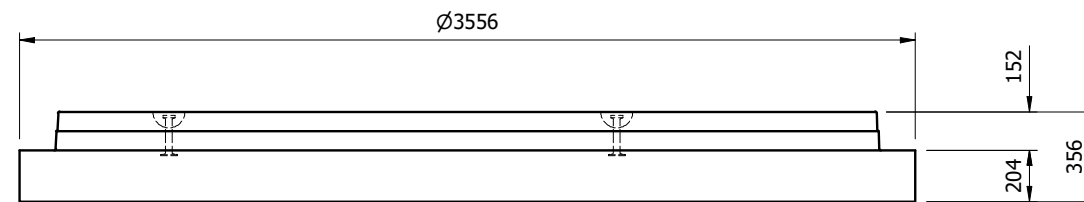
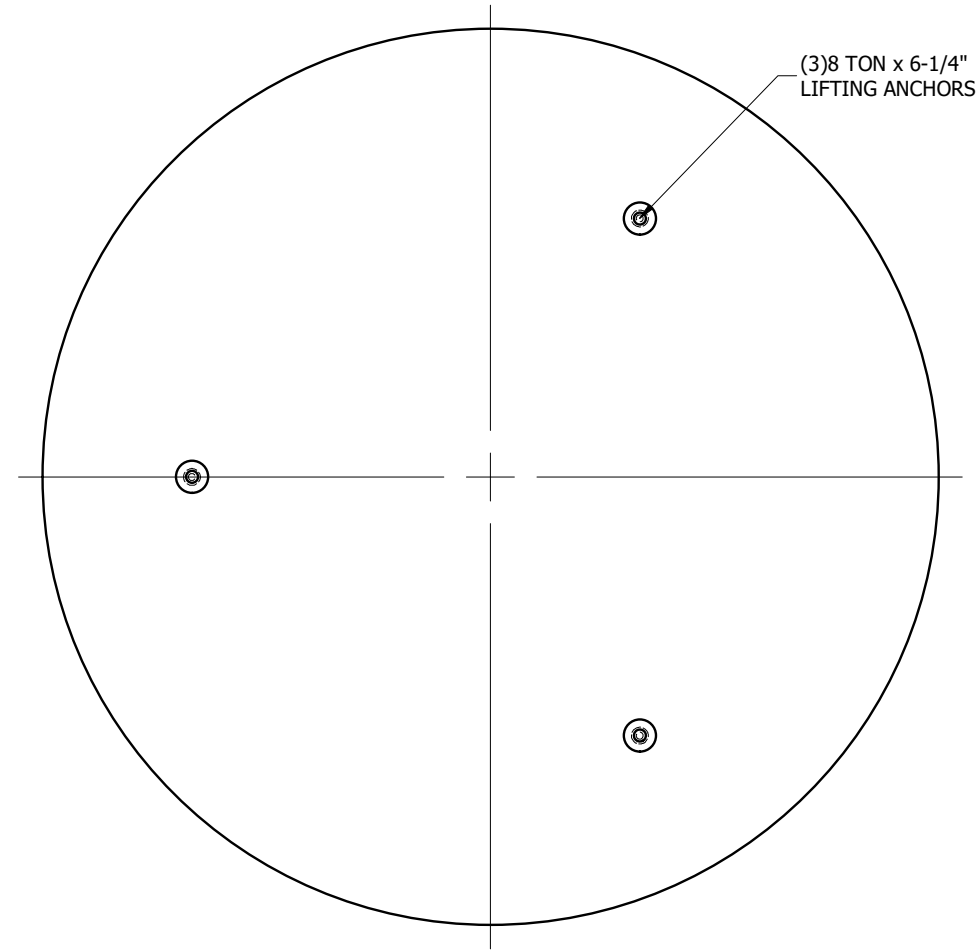

3000Ø SLAB BASE

**NOTES:**

- ALL DIMENSIONS ARE IN MILLIMETERS UNLESS OTHERWISE NOTED
- ALL ELEVATIONS ARE IN METERS ABOVE SEA LEVEL

APPROXIMATE WEIGHTS		
PIECE	lb	kg
3000	13,394	6,088

# STANDARD TEMPLATE

**PROPRIETARY AND CONFIDENTIAL:**

THE INFORMATION CONTAINED IN THIS DRAWING IS THE SOLE PROPERTY OF PRECON MANUFACTURING LTD. ANY REPRODUCTION IN PART OR AS A WHOLE WITHOUT THE WRITTEN PERMISSION OF PRECON MANUFACTURING LTD. IS PROHIBITED.



© Precon Manufacturing Ltd. www.precon.ca 1-800-661-8020

CONTRACTOR:

PROJECT:

LOCATION:

DESCRIPTION:  
**Ø3000 SLAB BASE**

STRUCTURE NAME:

DRAWN:	CHECKED:
DATE CREATED: 08/26/2020	REQUIRED:
LAST REVISION:	SCALE: 1:30
PROJECT NUMBER:	DRAWING:

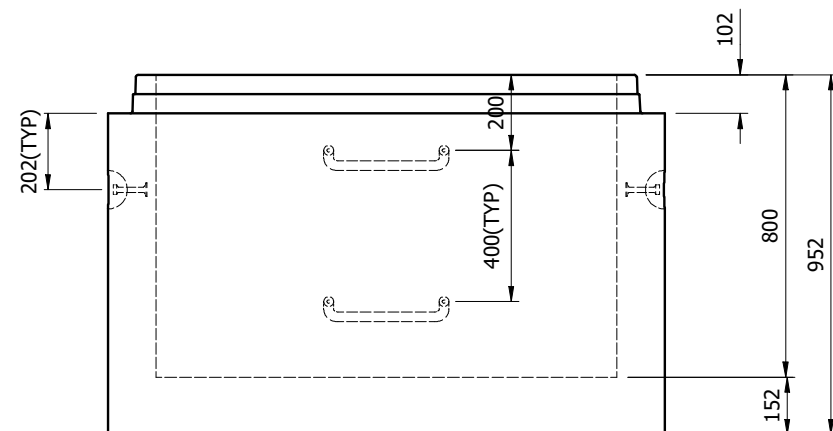
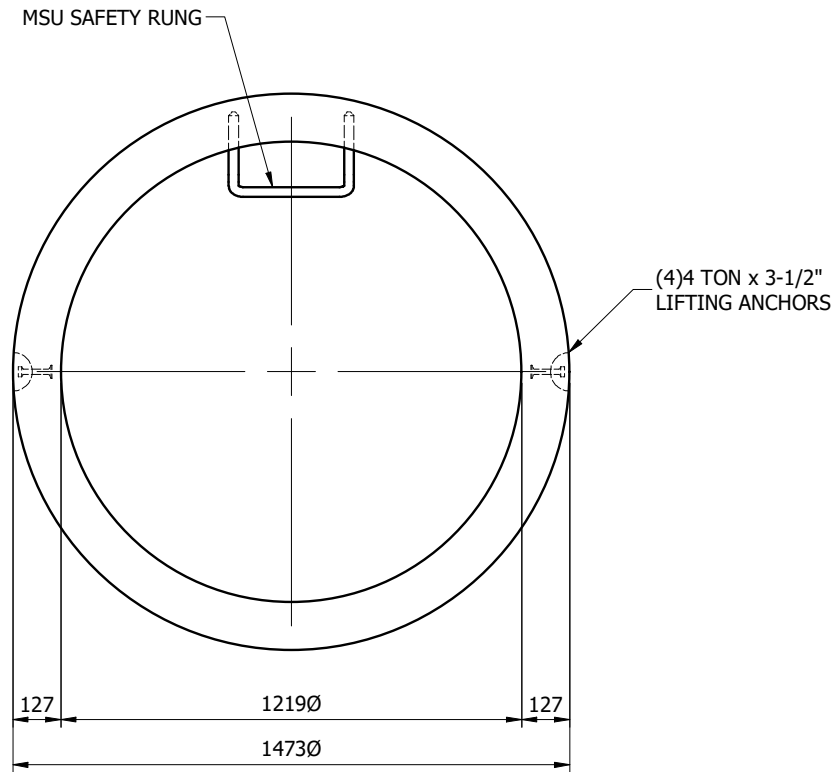

800 MONOBASE

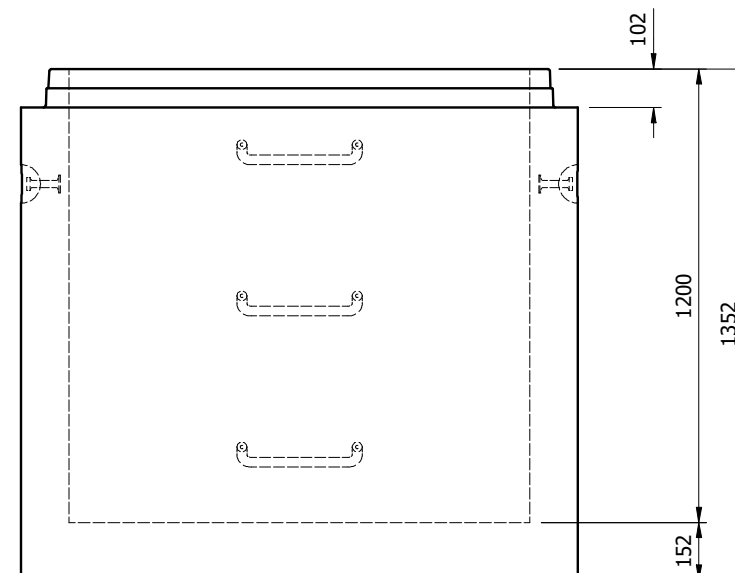

1200 MONOBASE

**NOTES:**

- ALL DIMENSIONS ARE IN MILLIMETERS UNLESS OTHERWISE NOTED
- ALL ELEVATIONS ARE IN METERS ABOVE SEA LEVEL

**TABLE OF WEIGHTS**

PIECE	lb	kg
800	3,487	1,585
1200	4,627	2,103

# STANDARD TEMPLATE

**PROPRIETARY AND CONFIDENTIAL:**

THE INFORMATION CONTAINED IN THIS DRAWING IS THE SOLE PROPERTY OF PRECON MANUFACTURING LTD. ANY REPRODUCTION IN PART OR AS A WHOLE WITHOUT THE WRITTEN PERMISSION OF PRECON MANUFACTURING LTD. IS PROHIBITED.



© Precon Manufacturing Ltd. www.precon.ca 1-800-661-8020

CONTRACTOR:	
PROJECT:	
LOCATION:	
DESCRIPTION: <b>1200Ø MONOLITHIC BASES</b>	
STRUCTURE NAME:	
DRAWN:	CHECKED:
DATE CREATED: 08/26/2020	REQUIRED:
LAST REVISION:	SCALE: 1:20
PROJECT NUMBER:	DRAWING:

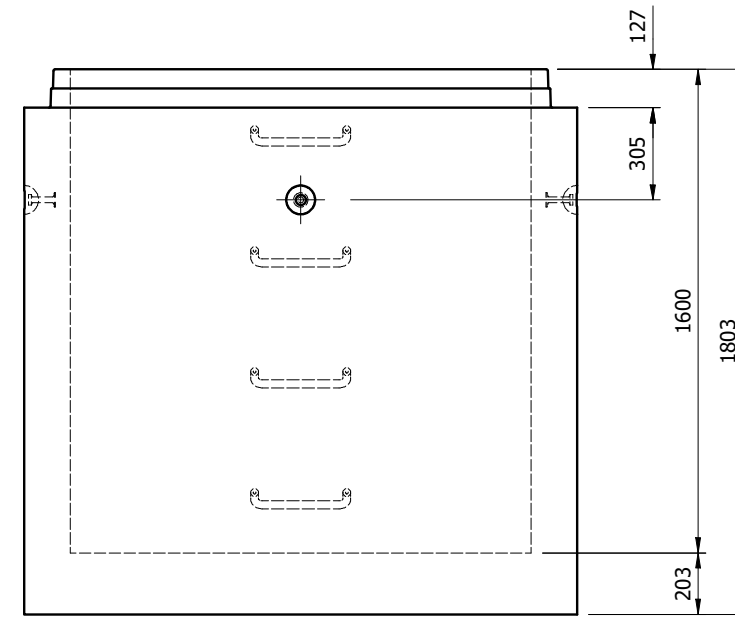
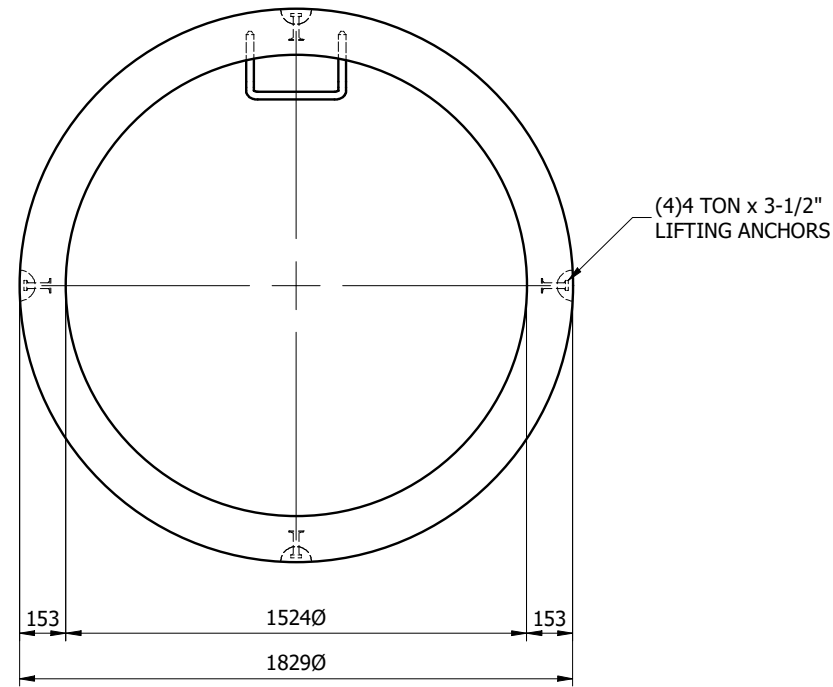

1600 MONOBASE

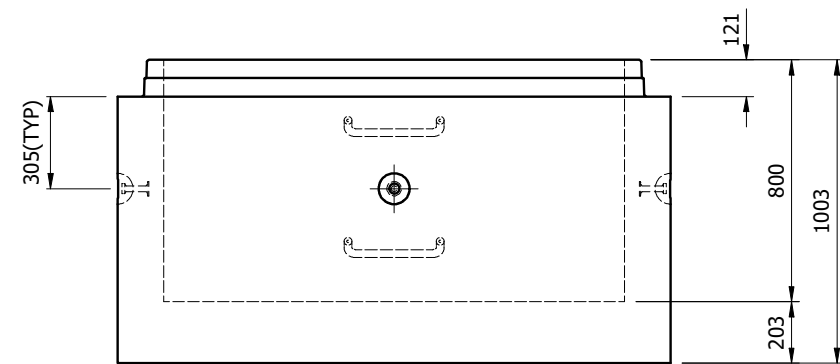

800 MONOBASE

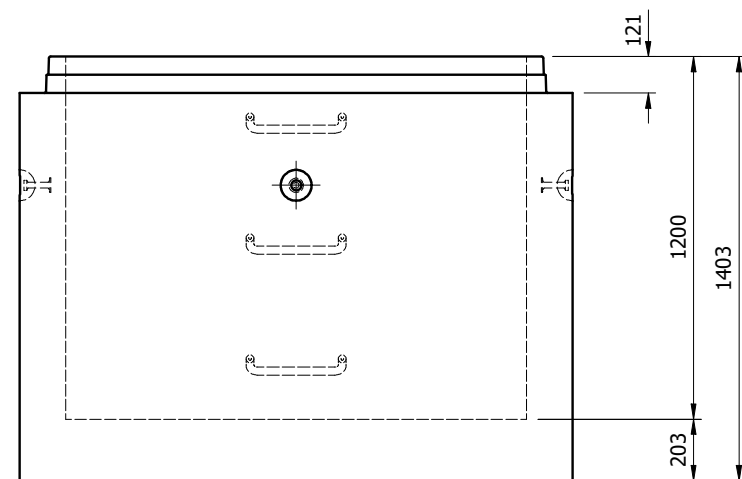

1200 MONOBASE

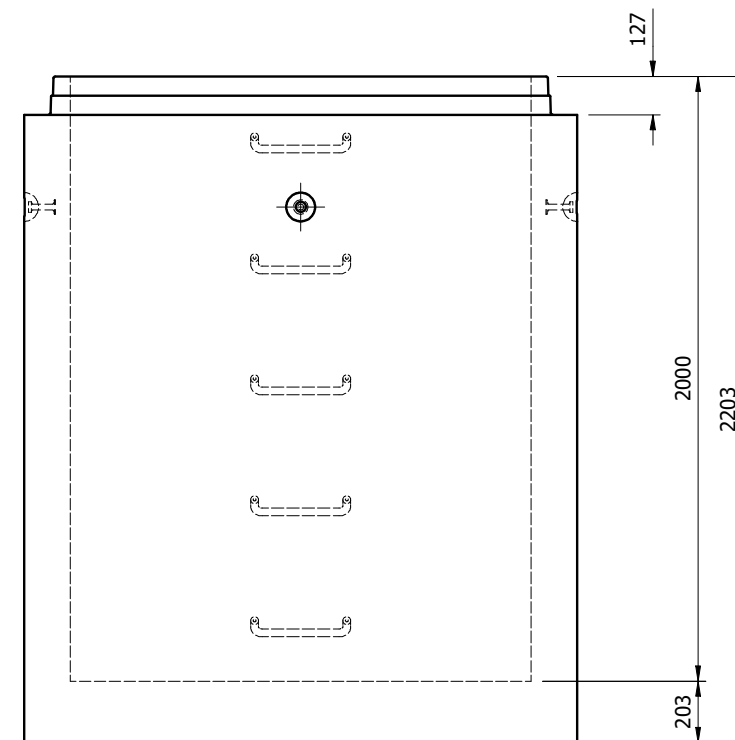

2000 MONOBASE

NOTES:

- ALL DIMENSIONS ARE IN MILLIMETERS UNLESS OTHERWISE NOTED
- ALL ELEVATIONS ARE IN METERS ABOVE SEA LEVEL

TABLE OF WEIGHTS

PIECE	lb	kg
800	5,895	2,680
1200	7,599	3,454
1600	9,303	4,229
2000	11,008	5,004

# STANDARD TEMPLATE

PROPRIETARY AND CONFIDENTIAL:

THE INFORMATION CONTAINED IN THIS DRAWING IS THE SOLE PROPERTY OF PRECON MANUFACTURING LTD. ANY REPRODUCTION IN PART OR AS A WHOLE WITHOUT THE WRITTEN PERMISSION OF PRECON MANUFACTURING LTD. IS PROHIBITED.



© Precon Manufacturing Ltd. www.precon.ca 1-800-661-8020

CONTRACTOR:

PROJECT:

LOCATION:

DESCRIPTION:  
**1500Ø MONOLITHIC BASES**

STRUCTURE NAME:

DRAWN:	CHECKED:
DATE CREATED: 08/26/2020	REQUIRED:
LAST REVISION:	SCALE: 1:25
PROJECT NUMBER:	DRAWING: <b>D0.1</b>

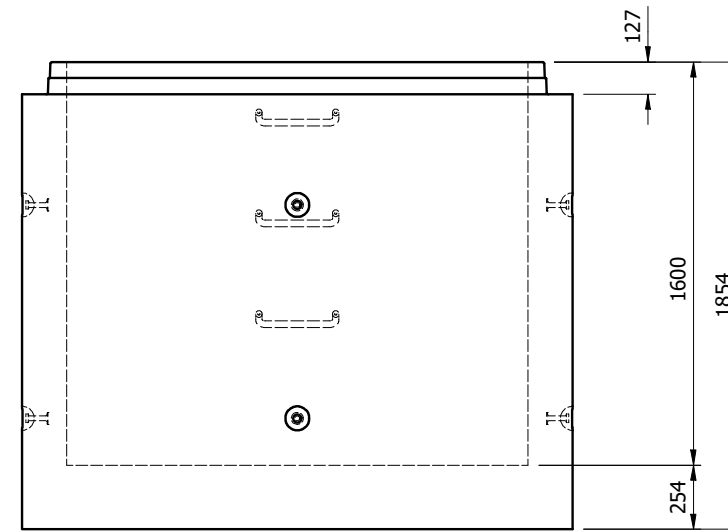
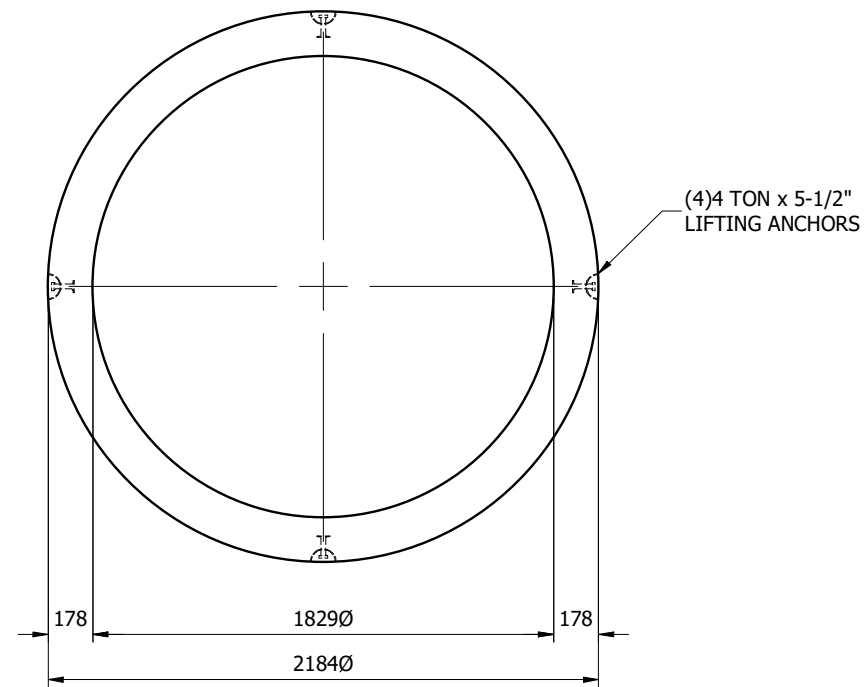

1600 MONOBASE

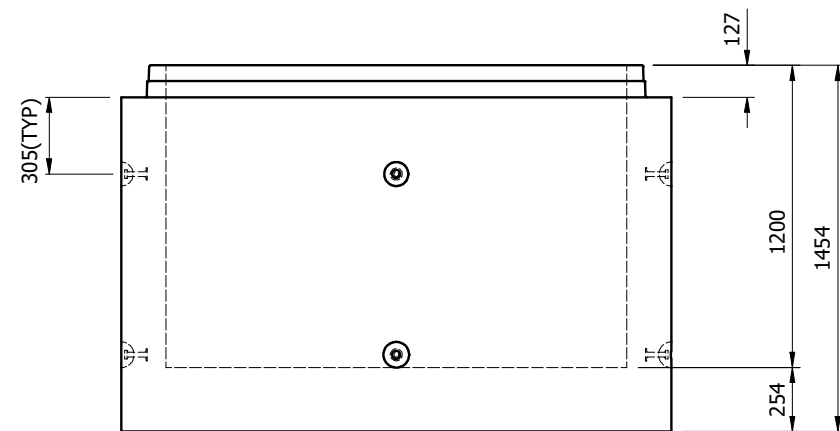

1200 MONOBASE

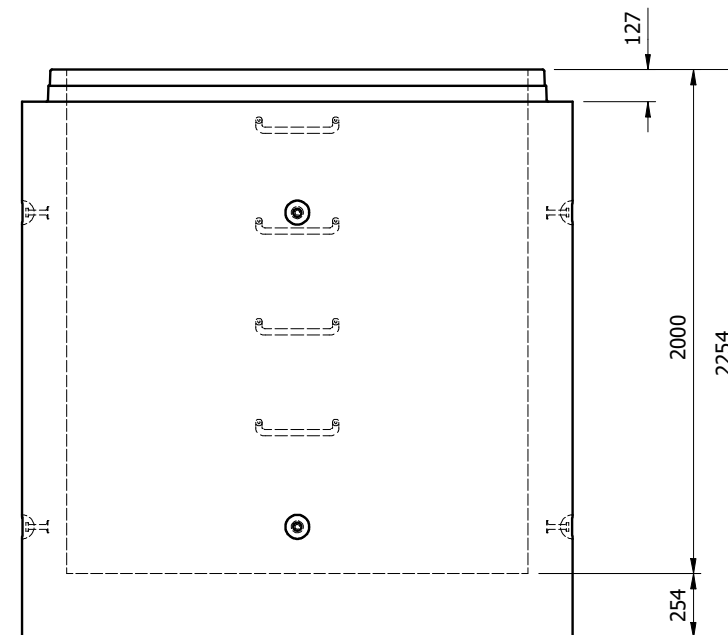

2000 MONOBASE

**NOTES:**

- ALL DIMENSIONS ARE IN MILLIMETERS UNLESS OTHERWISE NOTED
- ALL ELEVATIONS ARE IN METERS ABOVE SEA LEVEL

**TABLE OF WEIGHTS**

PIECE	lb	kg
1200	11,679	5,308
1600	14,030	6,377
2000	16,421	7,464

# STANDARD TEMPLATE

**PROPRIETARY AND CONFIDENTIAL:**

THE INFORMATION CONTAINED IN THIS DRAWING IS THE SOLE PROPERTY OF PRECON MANUFACTURING LTD. ANY REPRODUCTION IN PART OR AS A WHOLE WITHOUT THE WRITTEN PERMISSION OF PRECON MANUFACTURING LTD. IS PROHIBITED.



© Precon Manufacturing Ltd. www.precon.ca 1-800-661-8020

CONTRACTOR:

PROJECT:

LOCATION:

DESCRIPTION:  
**1800Ø MONOLITHIC BASES**

STRUCTURE NAME:

DRAWN: CHECKED:

DATE CREATED: 08/26/2020 REQUIRED:

LAST REVISION: SCALE: 1:30

PROJECT NUMBER: DRAWING: **D0.1**



**NOTES:**

- ALL DIMENSIONS ARE IN MILLIMETERS UNLESS OTHERWISE NOTED
- ALL ELEVATIONS ARE IN METERS ABOVE SEA LEVEL

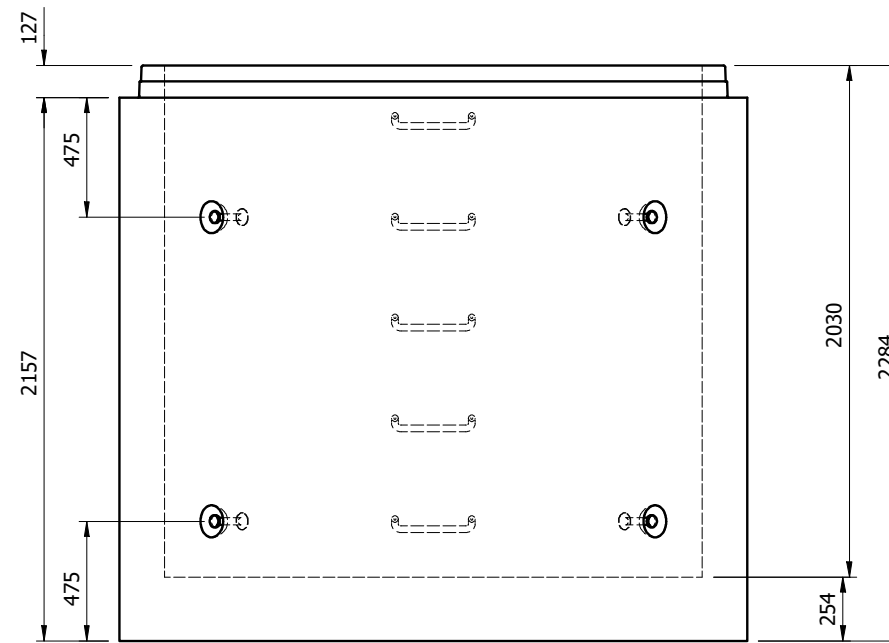
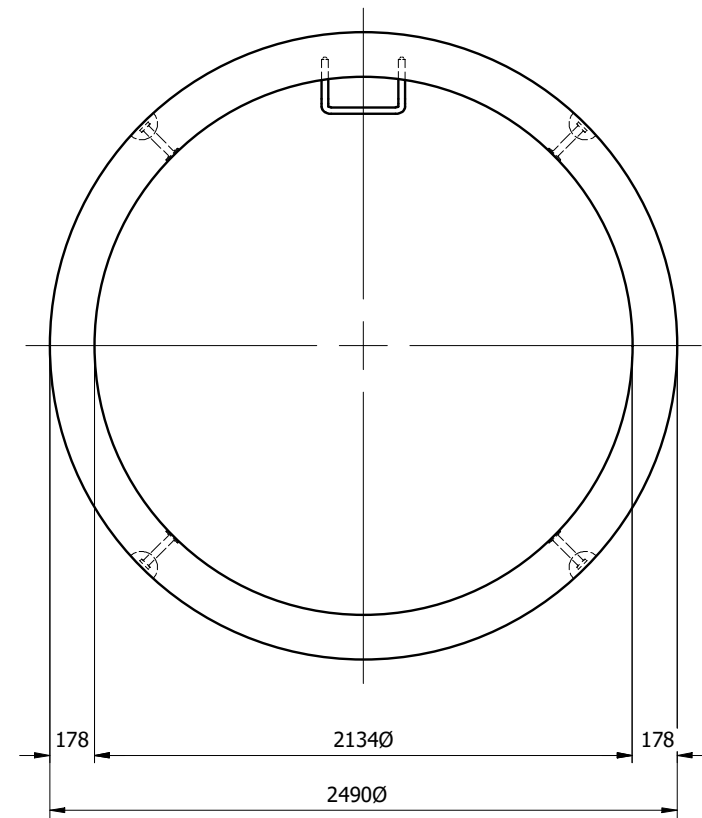

2000 HIGH

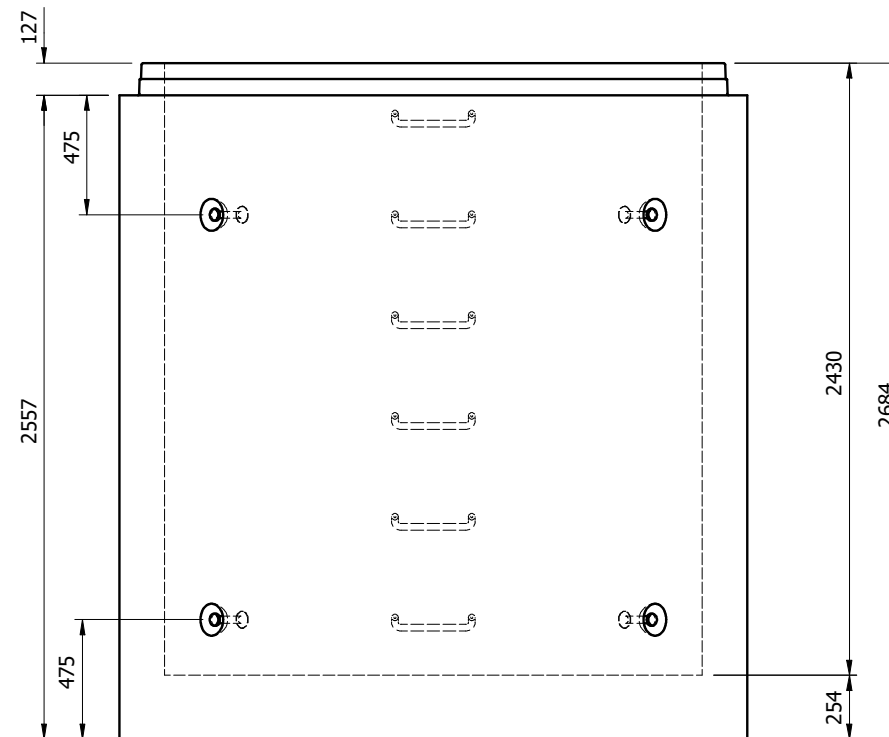

2400 HIGH

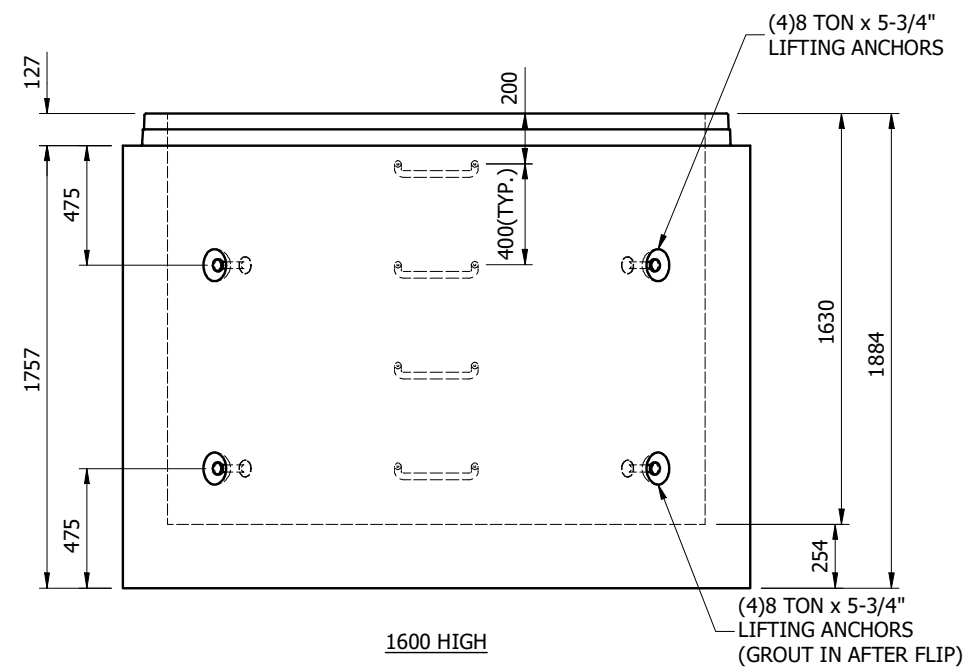

1600 HIGH

APPROXIMATE WEIGHTS			
PIECE	lb	kg	BURY DEPTH
1630	17,300	7,864	-
2030	20,042	9,110	-
2430	22,784	10,356	-

# STANDARD TEMPLATE

**PROPRIETARY AND CONFIDENTIAL:**

THE INFORMATION CONTAINED IN THIS DRAWING IS THE SOLE PROPERTY OF PRECON MANUFACTURING LTD. ANY REPRODUCTION IN PART OR AS A WHOLE WITHOUT THE WRITTEN PERMISSION OF PRECON MANUFACTURING LTD. IS PROHIBITED.



© Precon Manufacturing Ltd. www.precon.ca 1-800-661-8020

CONTRACTOR:	
<b>PRECON</b>	
PROJECT:	
-	
LOCATION:	
-	
DESCRIPTION:	
<b>2134Ø MONOBASES</b>	
STRUCTURE NAME:	
-	
DRAWN:	CHECKED:
DATE CREATED: 10/25/2021	REQUIRED:
LAST REVISION:	SCALE: 1:30
PROJECT NUMBER: -	DRAWING: <b>D0.4</b>

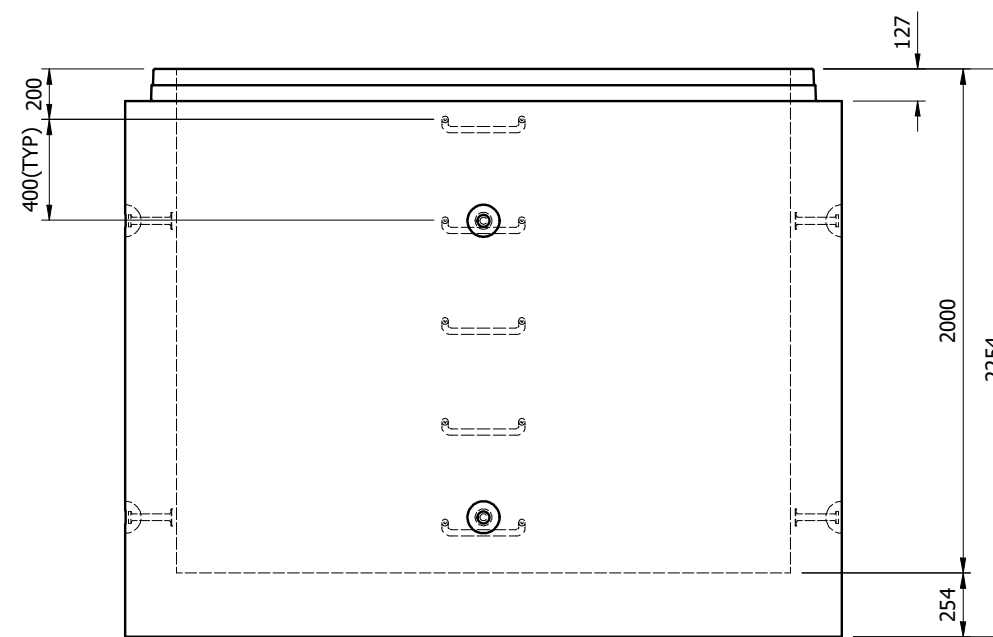
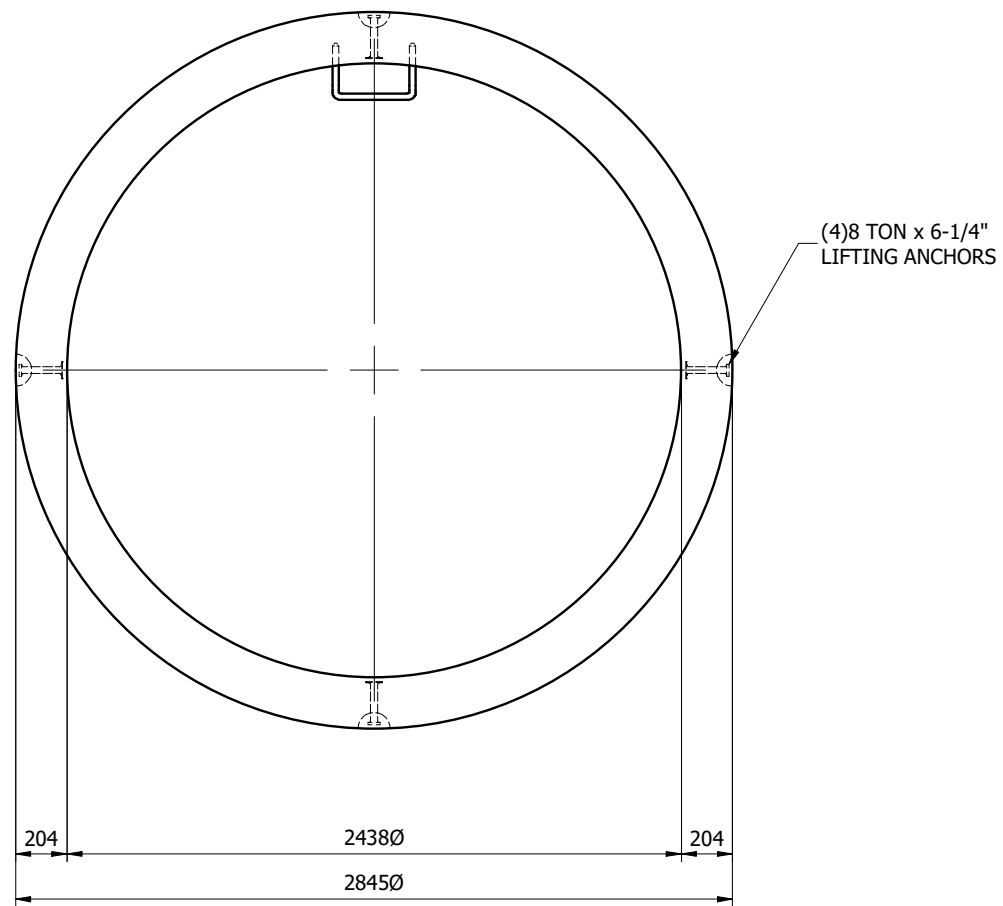

2000 MONOBASE

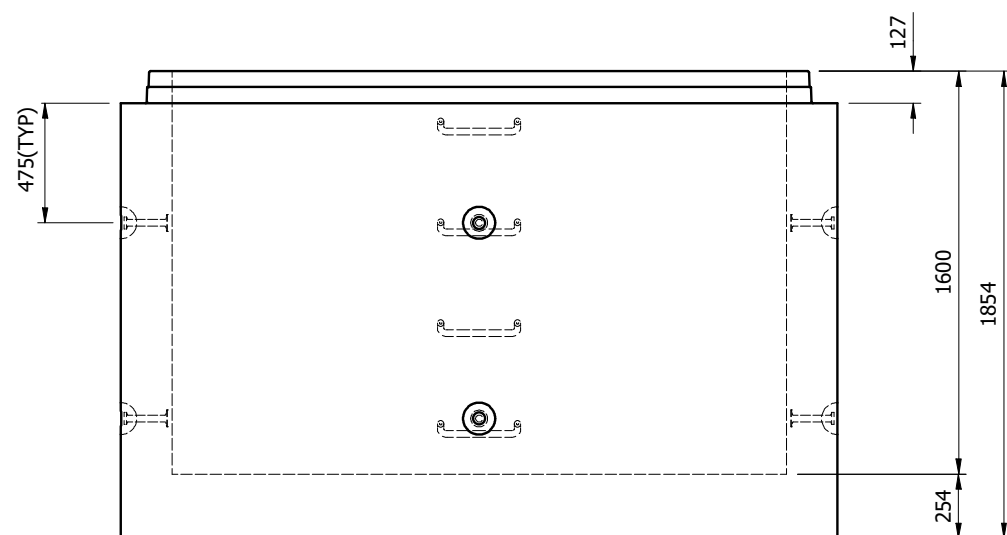

1600 MONOBASE

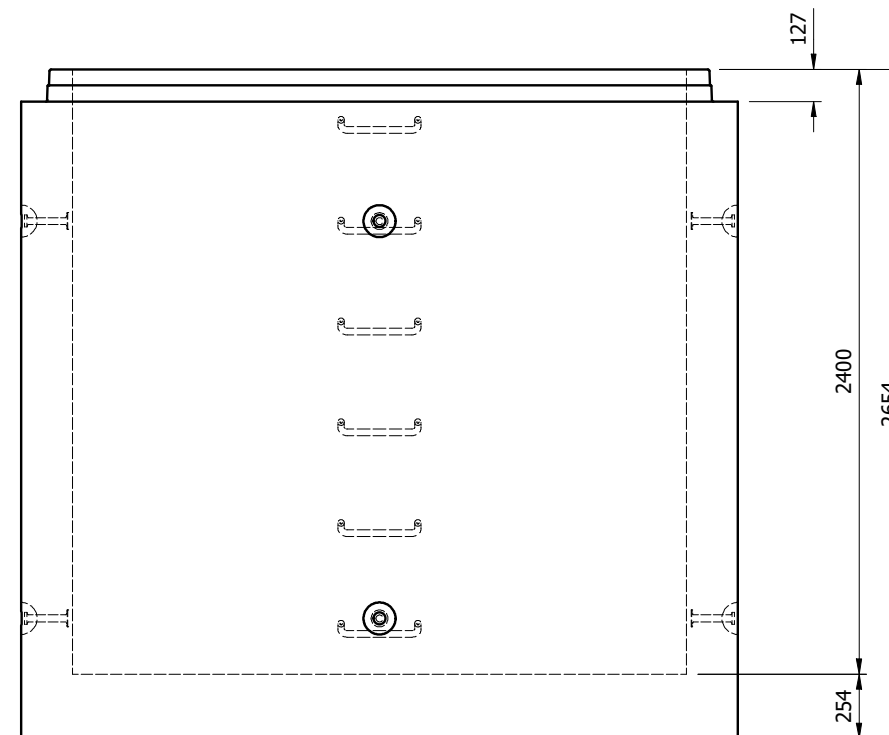

2400 MONOBASE

**NOTES:**

- ALL DIMENSIONS ARE IN MILLIMETERS UNLESS OTHERWISE NOTED
- ALL ELEVATIONS ARE IN METERS ABOVE SEA LEVEL

**TABLE OF WEIGHTS**

PIECE	lb	kg
1600	22,292	10,133
2000	25,881	11,764
2400	29,471	13,396

# STANDARD TEMPLATE

**PROPRIETARY AND CONFIDENTIAL:**

THE INFORMATION CONTAINED IN THIS DRAWING IS THE SOLE PROPERTY OF PRECON MANUFACTURING LTD. ANY REPRODUCTION IN PART OR AS A WHOLE WITHOUT THE WRITTEN PERMISSION OF PRECON MANUFACTURING LTD. IS PROHIBITED.



© Precon Manufacturing Ltd. www.precon.ca 1-800-661-8020

CONTRACTOR:	
PROJECT:	
LOCATION:	
DESCRIPTION: <b>2400Ø MONOLITHIC BASES</b>	
STRUCTURE NAME:	
DRAWN:	CHECKED:
DATE CREATED: 08/26/2020	REQUIRED:
LAST REVISION:	SCALE: 1:30
PROJECT NUMBER:	DRAWING: <b>D0.1</b>

**NOTES:**

- ALL DIMENSIONS ARE IN MILLIMETERS UNLESS OTHERWISE NOTED
- ALL ELEVATIONS ARE IN METERS ABOVE SEA LEVEL

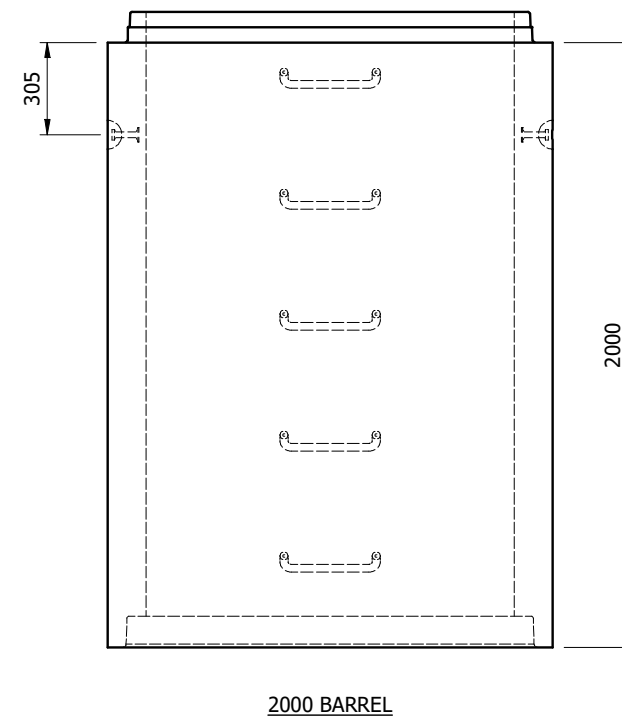
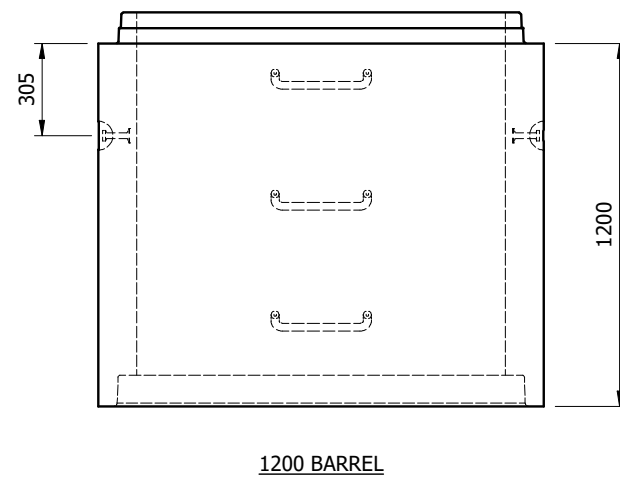
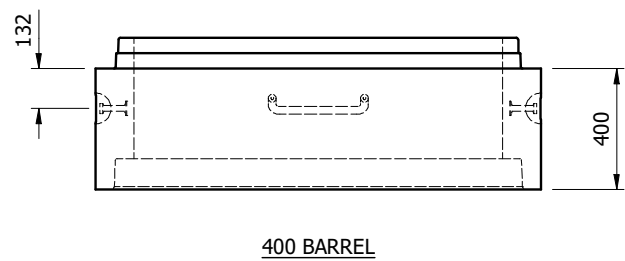
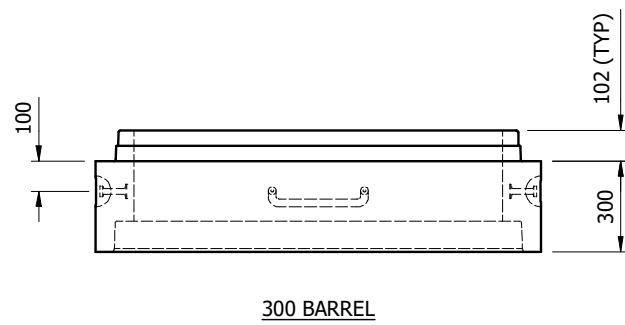
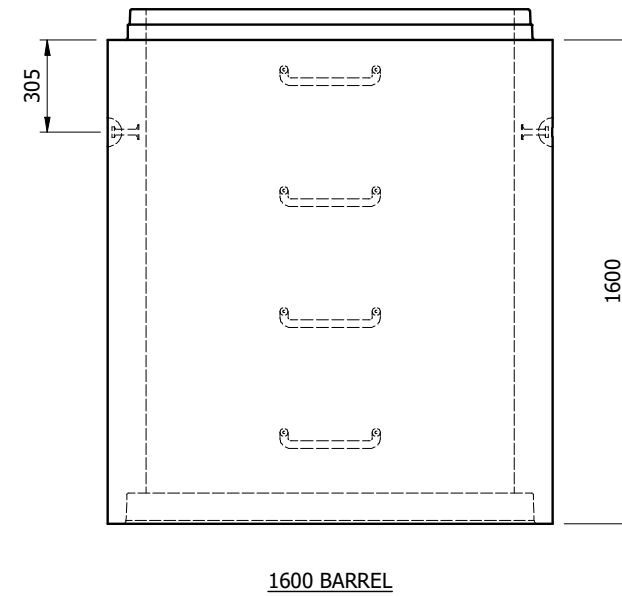
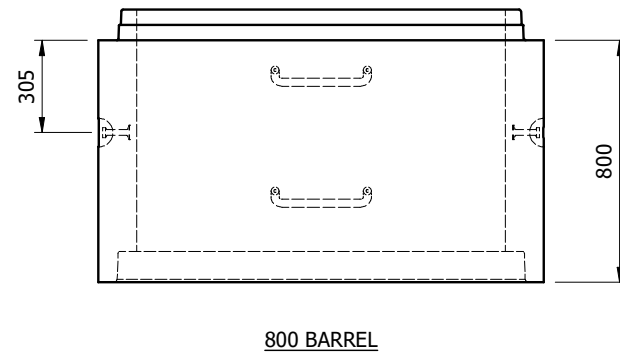
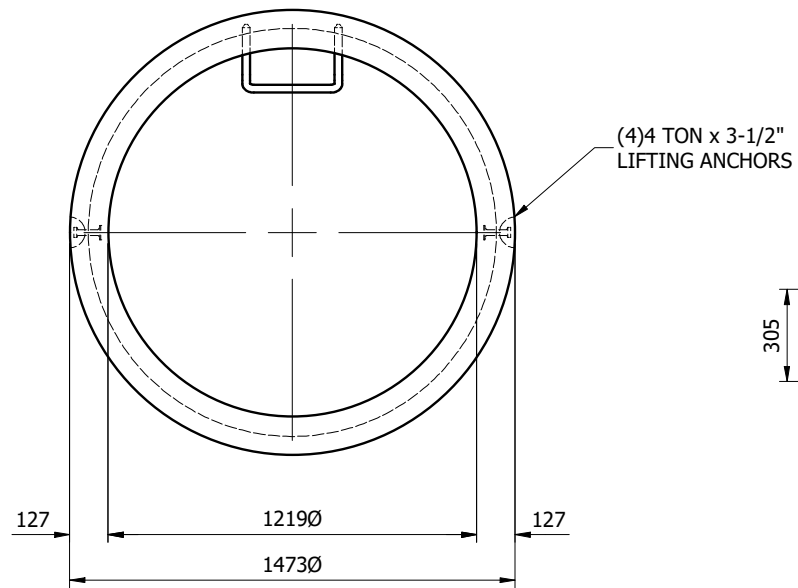

**TABLE OF WEIGHTS**

PIECE	lb	kg
300	836	380
400	1,121	510
800	2,261	1,028
1200	3,401	1,546
1600	4,542	2,065
2000	5,682	2,583

# STANDARD TEMPLATE

**PROPRIETARY AND CONFIDENTIAL:**  
 THE INFORMATION CONTAINED IN THIS DRAWING IS THE SOLE PROPERTY OF PRECON MANUFACTURING LTD. ANY REPRODUCTION IN PART OR AS A WHOLE WITHOUT THE WRITTEN PERMISSION OF PRECON MANUFACTURING LTD. IS PROHIBITED.



© Precon Manufacturing Ltd. www.precon.ca 1-800-661-8020

CONTRACTOR:

PROJECT:

LOCATION:

DESCRIPTION:  
**1200Ø BARRELS**

STRUCTURE NAME:

DRAWN: CHECKED:

DATE CREATED: 08/26/2020 REQUIRED:

LAST REVISION: SCALE: 1:25

PROJECT NUMBER: DRAWING: **D0.1**

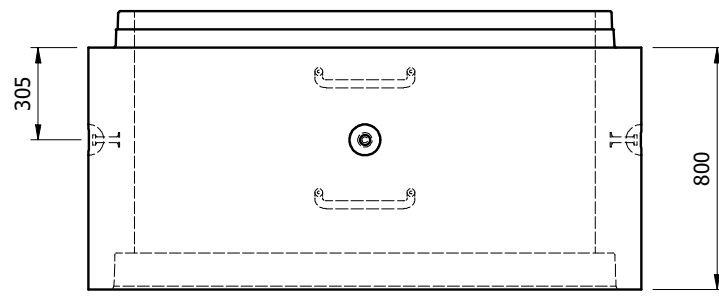
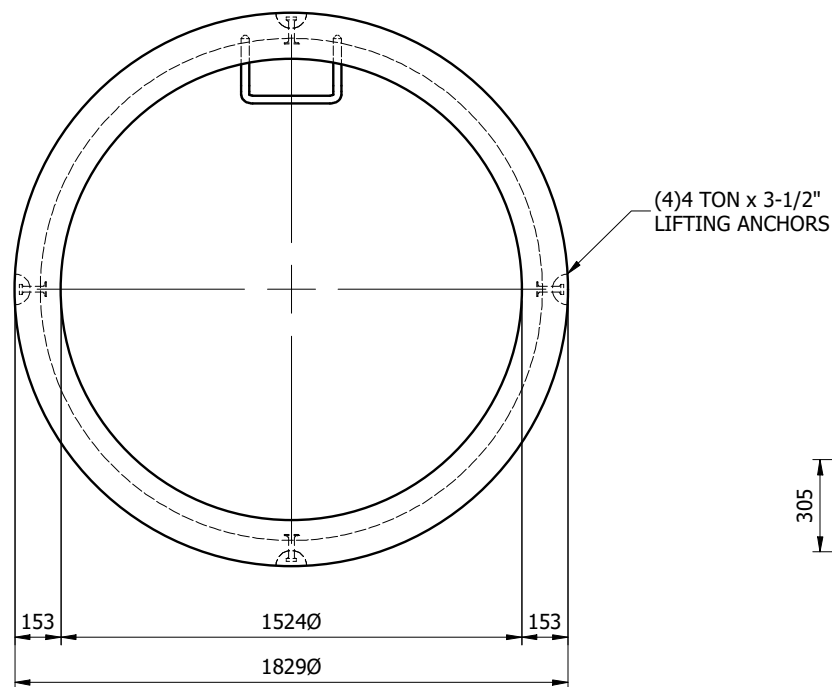

800 BARREL

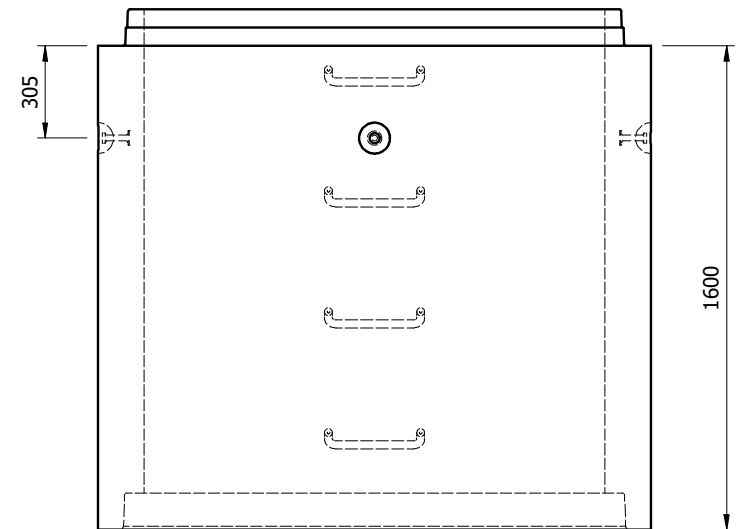

1600 BARREL

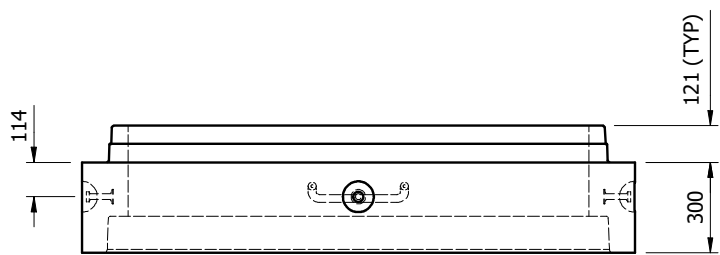

300 BARREL

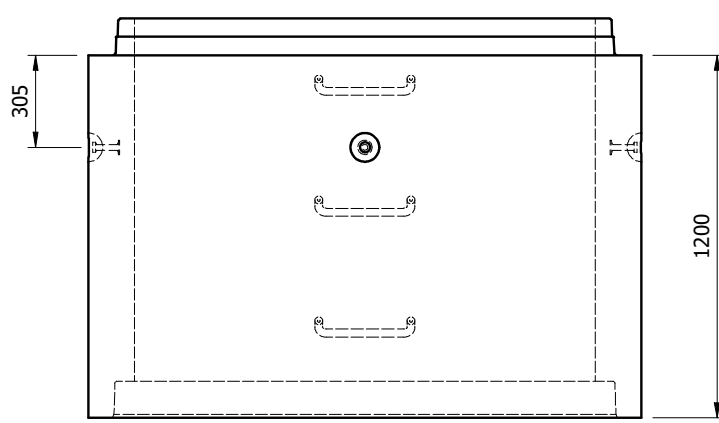

1200 BARREL

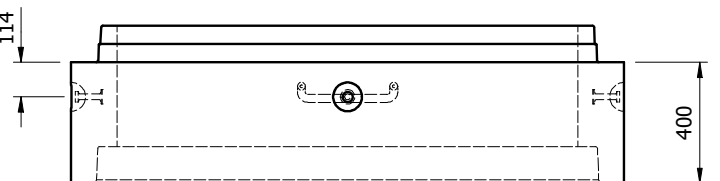

400 BARREL

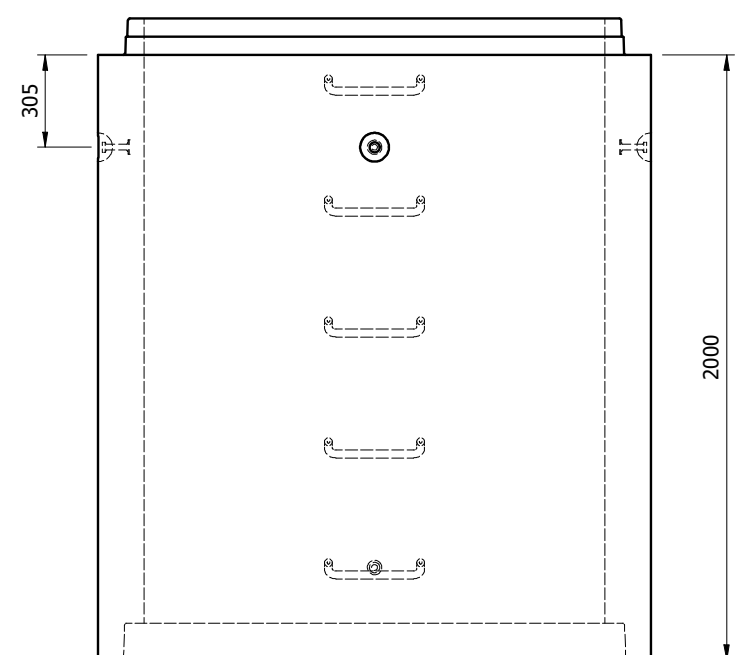

2000 BARREL

**NOTES:**  
 - ALL DIMENSIONS ARE IN MILLIMETERS UNLESS OTHERWISE NOTED  
 - ALL ELEVATIONS ARE IN METERS ABOVE SEA LEVEL

TABLE OF WEIGHTS		
PIECE	lb	kg
300	1,247	567
400	1,673	760
800	3,377	1,535
1200	5,081	2,310
1600	6,771	3,078
2000	8,490	3,859

# STANDARD TEMPLATE

**PROPRIETARY AND CONFIDENTIAL:**  
 THE INFORMATION CONTAINED IN THIS DRAWING IS THE SOLE PROPERTY OF PRECON MANUFACTURING LTD. ANY REPRODUCTION IN PART OR AS A WHOLE WITHOUT THE WRITTEN PERMISSION OF PRECON MANUFACTURING LTD. IS PROHIBITED.



© Precon Manufacturing Ltd. www.precon.ca 1-800-661-8020

CONTRACTOR: \_\_\_\_\_

PROJECT: \_\_\_\_\_

LOCATION: \_\_\_\_\_

DESCRIPTION:  
**1500Ø BARRELS**

STRUCTURE NAME: \_\_\_\_\_

DRAWN:	CHECKED:
DATE CREATED: 08/26/2020	REQUIRED:
LAST REVISION:	SCALE: 1:25
PROJECT NUMBER:	DRAWING: <b>D0.1</b>

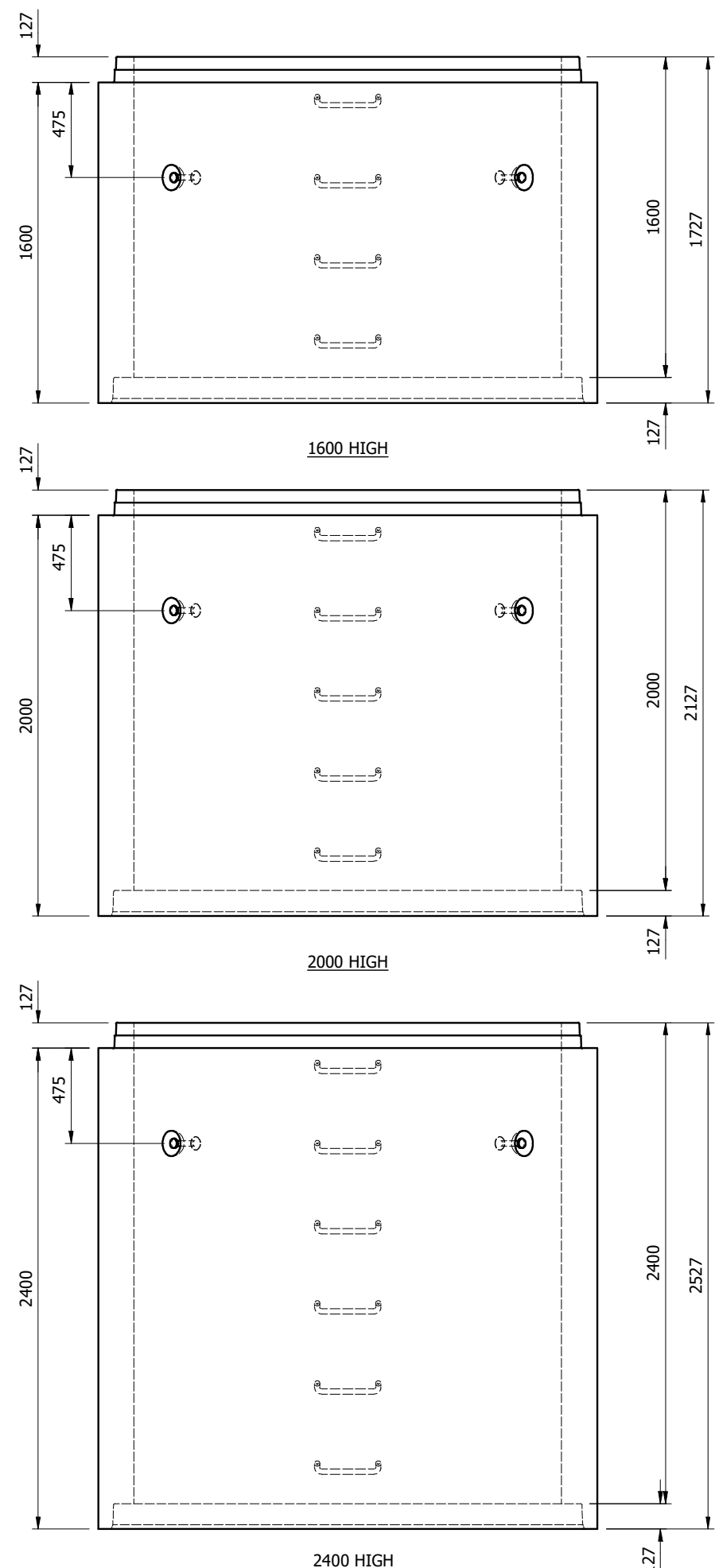
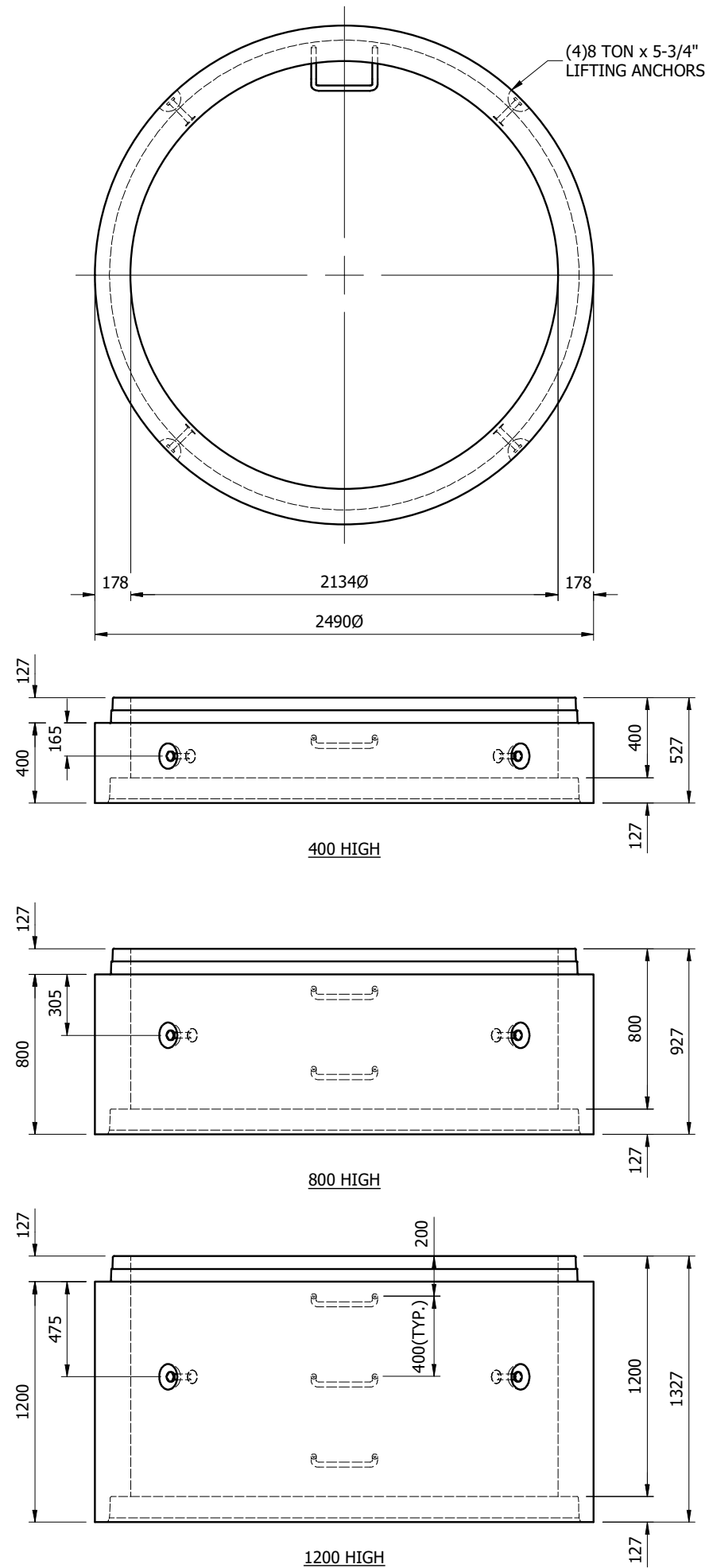

**NOTES:**  
 - ALL DIMENSIONS ARE IN MILLIMETERS UNLESS OTHERWISE NOTED  
 - ALL ELEVATIONS ARE IN METERS ABOVE SEA LEVEL

APPROXIMATE WEIGHTS			
PIECE	lb	kg	BURY DEPTH
400	2,683	1,220	-
800	5,426	2,466	-
1200	8,168	3,713	-
1600	10,910	4,959	-
2000	13,652	6,205	-
2400	16,394	7,452	-

# STANDARD TEMPLATE

**PROPRIETARY AND CONFIDENTIAL:**  
 THE INFORMATION CONTAINED IN THIS DRAWING IS THE SOLE PROPERTY OF PRECON MANUFACTURING LTD. ANY REPRODUCTION IN PART OR AS A WHOLE WITHOUT THE WRITTEN PERMISSION OF PRECON MANUFACTURING LTD. IS PROHIBITED.



© Precon Manufacturing Ltd. www.precon.ca 1-800-661-8020

CONTRACTOR:		<b>PRECON</b>	
PROJECT:		-	
LOCATION:		-	
DESCRIPTION:		<b>2134Ø BARRELS</b>	
STRUCTURE NAME:		-	
DRAWN:	CHECKED:		
DATE CREATED:	10/25/2021	REQUIRED:	
LAST REVISION:		SCALE:	1:30
PROJECT NUMBER:	-	DRAWING:	<b>D0.2</b>

**NOTES:**

- ALL DIMENSIONS ARE IN MILLIMETERS UNLESS OTHERWISE NOTED
- ALL ELEVATIONS ARE IN METERS ABOVE SEA LEVEL

TABLE OF WEIGHTS		
PIECE	lb	kg
400	3,527	1,603
800	7,117	3,235
1200	10,708	4,867
1600	14,298	6,499
2000	17,888	8,131
2400	21,478	9,763

# STANDARD TEMPLATE

**PROPRIETARY AND CONFIDENTIAL:**

THE INFORMATION CONTAINED IN THIS DRAWING IS THE SOLE PROPERTY OF PRECON MANUFACTURING LTD. ANY REPRODUCTION IN PART OR AS A WHOLE WITHOUT THE WRITTEN PERMISSION OF PRECON MANUFACTURING LTD. IS PROHIBITED.



© Precon Manufacturing Ltd. www.precon.ca 1-800-661-8020

CONTRACTOR:

PROJECT:

LOCATION:

DESCRIPTION:  
**2400Ø BARRELS**

STRUCTURE NAME:

DRAWN: CHECKED:

DATE CREATED: 08/26/2020 REQUIRED:

LAST REVISION: SCALE: 1:35

PROJECT NUMBER: DRAWING: **D0.1**

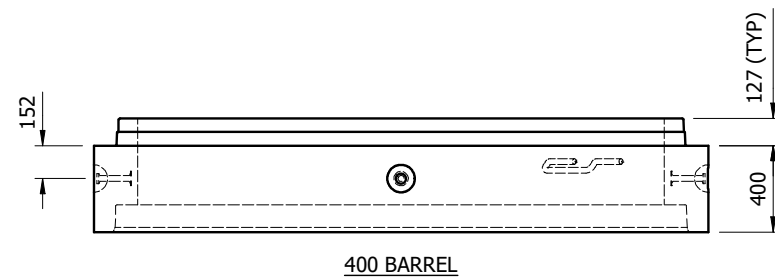
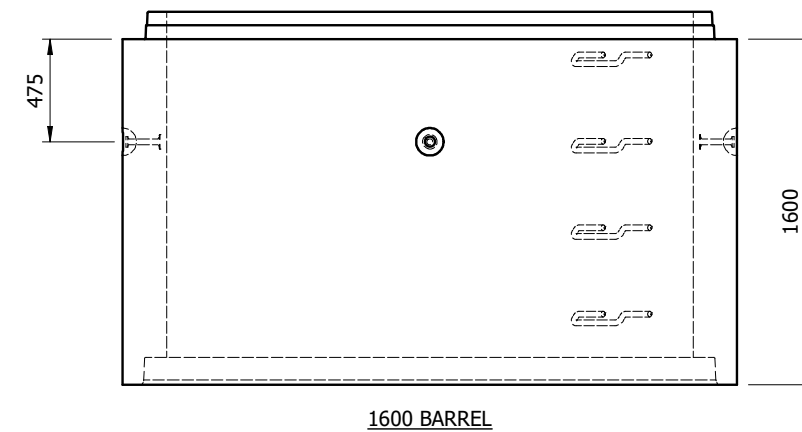
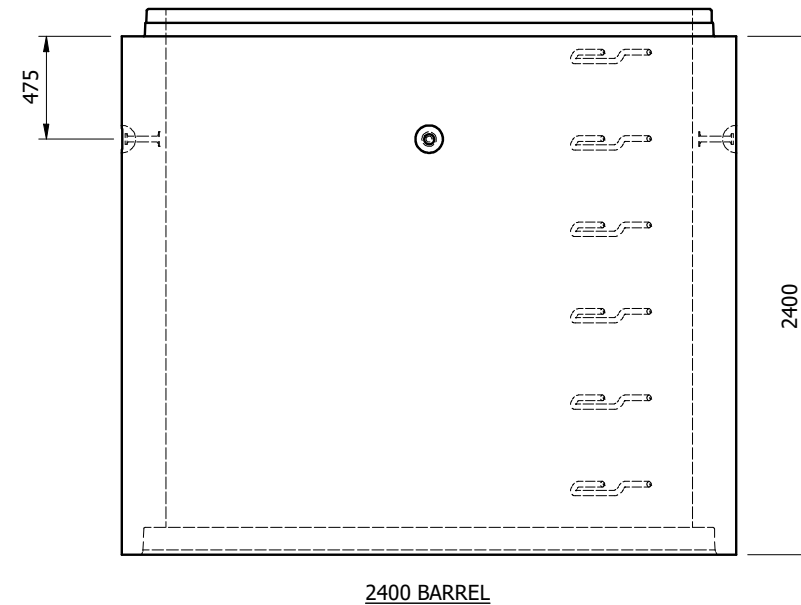
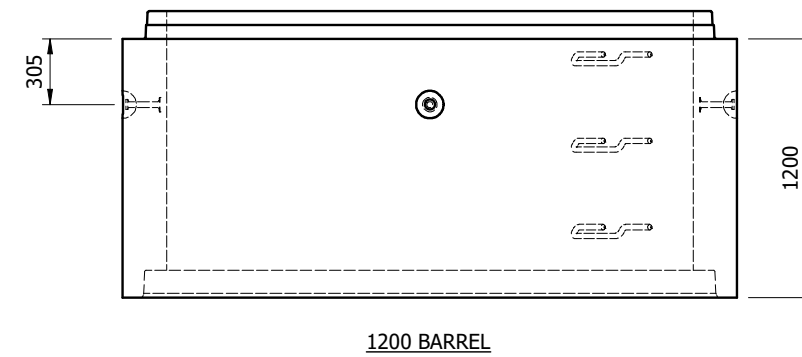
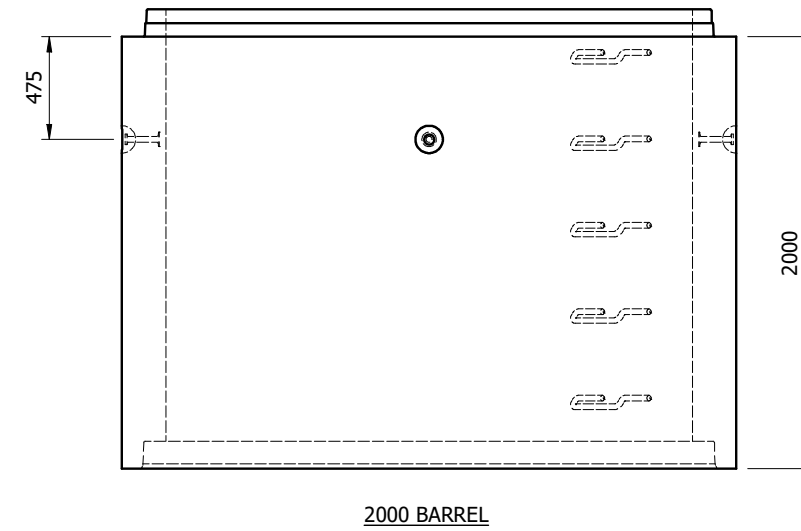
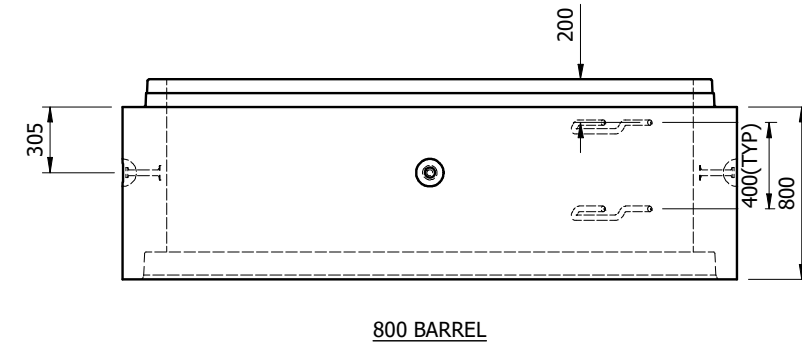
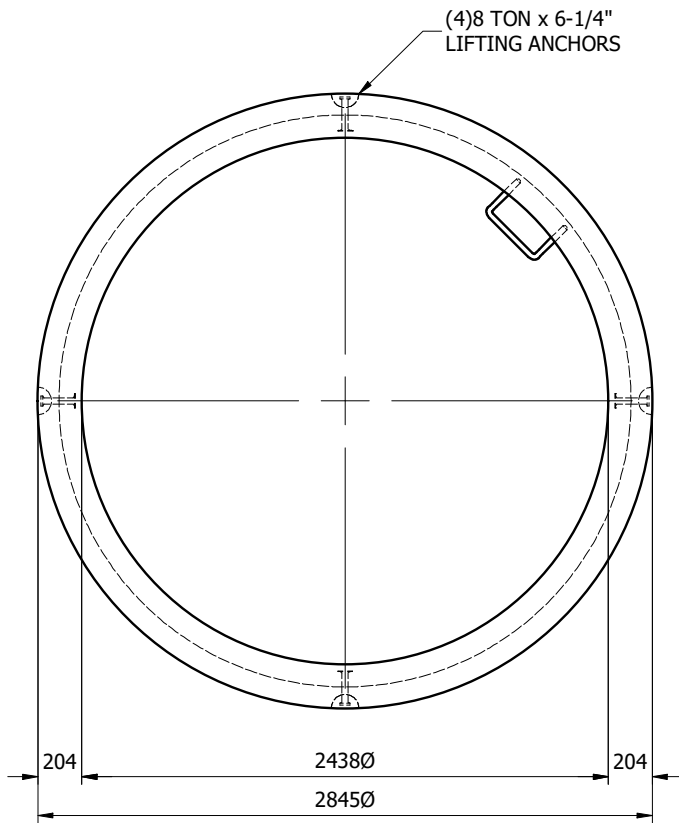

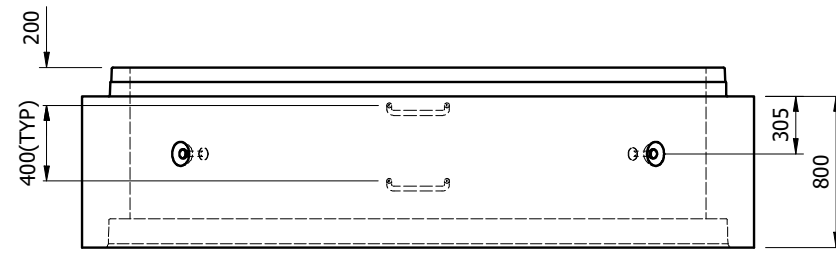
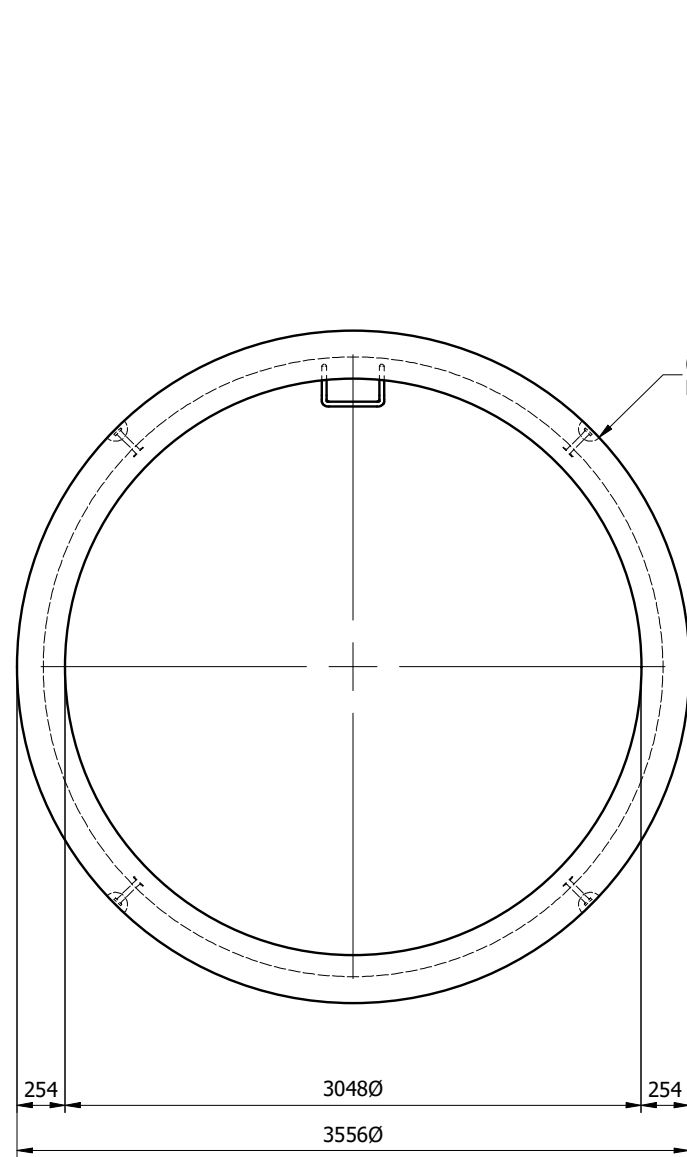

800 BARREL

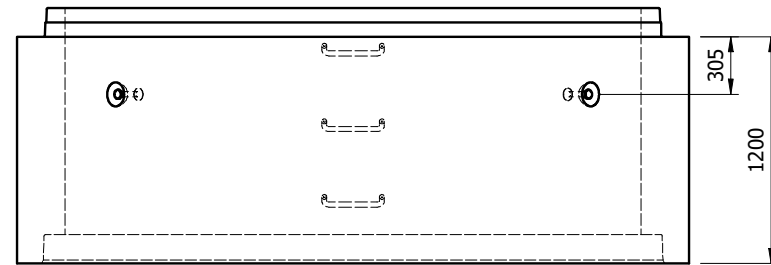

1200 BARREL

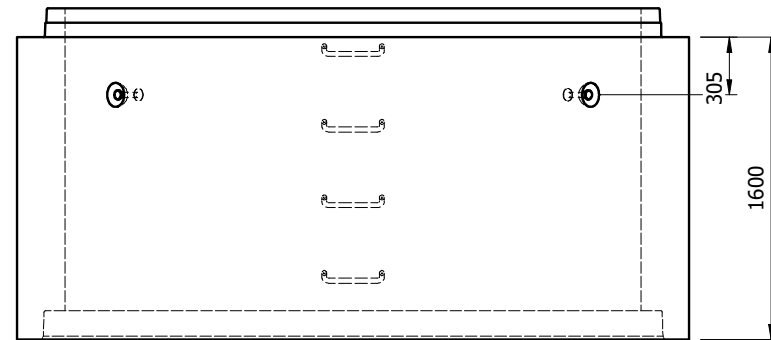

1600 BARREL

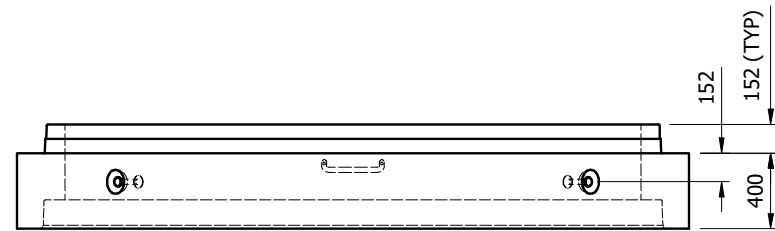

400 BARREL

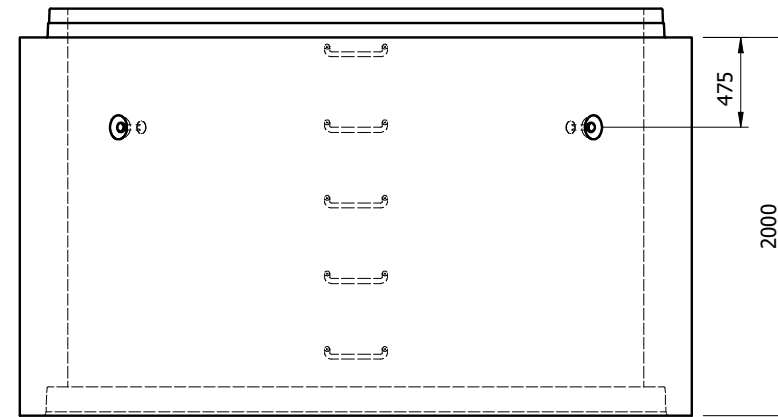

2000 BARREL

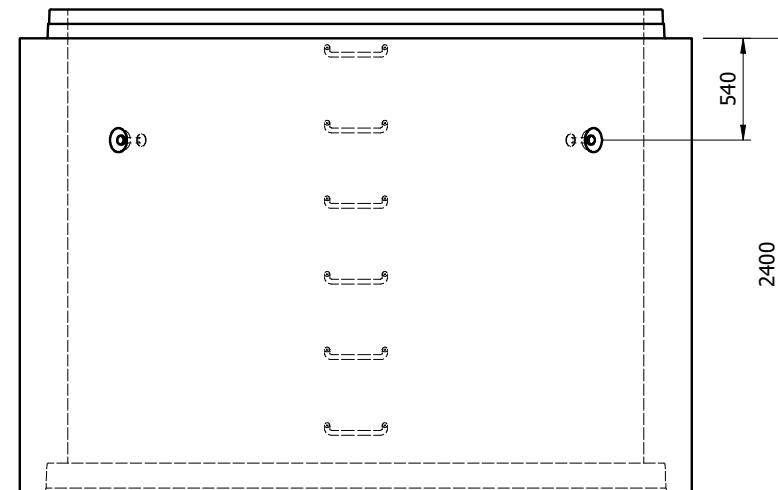

2400 BARREL

**NOTES:**

- ALL DIMENSIONS ARE IN MILLIMETERS UNLESS OTHERWISE NOTED
- ALL ELEVATIONS ARE IN METERS ABOVE SEA LEVEL

**APPROXIMATE WEIGHTS**

PIECE	lb	kg
400	5,487	2,494
800	11,073	5,033
1200	16,659	7,572
1600	22,245	10,111
2000	27,830	12,650
2400	33,416	15,189

# STANDARD TEMPLATE

**PROPRIETARY AND CONFIDENTIAL:**

THE INFORMATION CONTAINED IN THIS DRAWING IS THE SOLE PROPERTY OF PRECON MANUFACTURING LTD. ANY REPRODUCTION IN PART OR AS A WHOLE WITHOUT THE WRITTEN PERMISSION OF PRECON MANUFACTURING LTD. IS PROHIBITED.



© Precon Manufacturing Ltd. www.precon.ca 1-800-661-8020

CONTRACTOR: \_\_\_\_\_

PROJECT: \_\_\_\_\_

LOCATION: \_\_\_\_\_

DESCRIPTION: **3000Ø BARRELS**

STRUCTURE NAME: \_\_\_\_\_

DRAWN:	CHECKED:
DATE CREATED: 08/26/2020	REQUIRED:
LAST REVISION:	SCALE: 1:40
PROJECT NUMBER:	DRAWING: <b>D0.1</b>

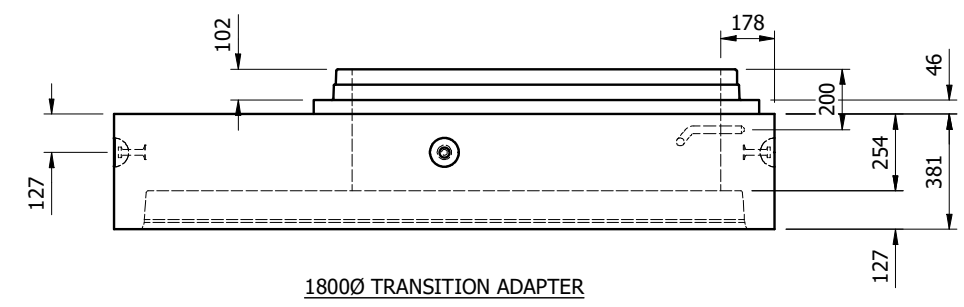
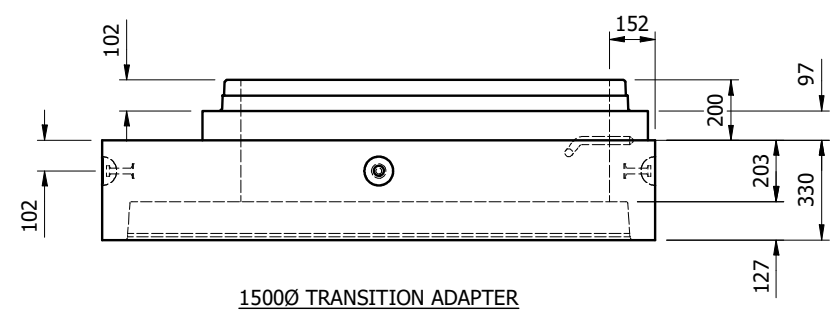
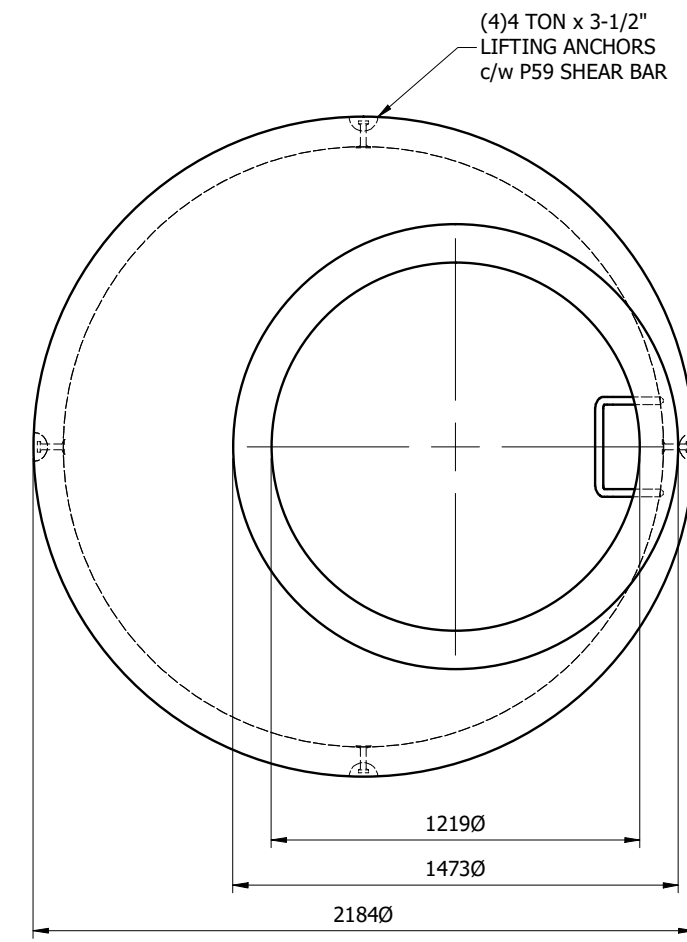
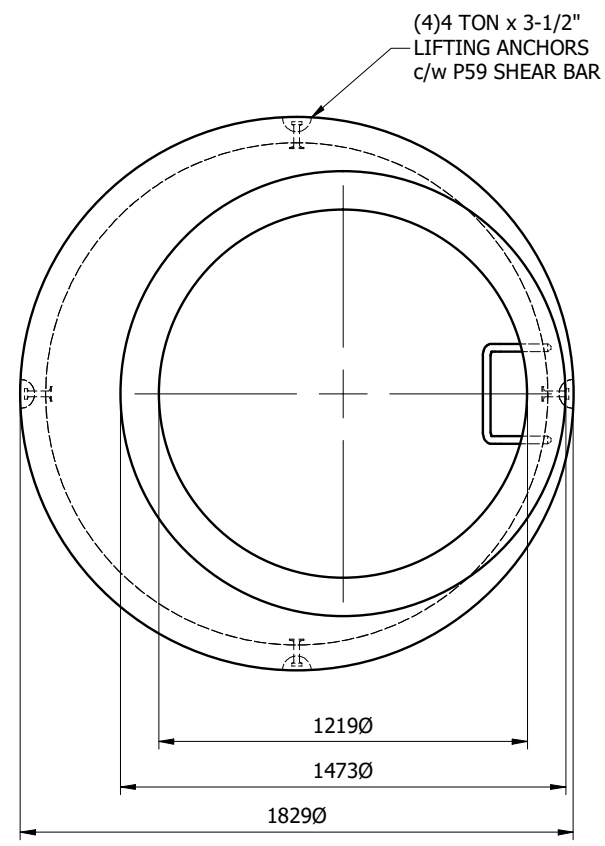

**NOTES:**  
 - ALL DIMENSIONS ARE IN MILLIMETERS UNLESS OTHERWISE NOTED  
 - ALL ELEVATIONS ARE IN METERS ABOVE SEA LEVEL

APPROXIMATE WEIGHTS		
PIECE	lb	kg
1500	2,294	1,043
1800	4,174	1,897

# STANDARD TEMPLATE

**PROPRIETARY AND CONFIDENTIAL:**  
 THE INFORMATION CONTAINED IN THIS DRAWING IS THE SOLE PROPERTY OF PRECON MANUFACTURING LTD. ANY REPRODUCTION IN PART OR AS A WHOLE WITHOUT THE WRITTEN PERMISSION OF PRECON MANUFACTURING LTD. IS PROHIBITED.



CONTRACTOR:

PROJECT:

LOCATION:

DESCRIPTION:  
**TRANSITION ADAPTERS**

STRUCTURE NAME:

DRAWN:	CHECKED:
DATE CREATED: 08/26/2020	REQUIRED:
LAST REVISION:	SCALE: 1:25
PROJECT NUMBER:	DRAWING: <b>D0.1</b>

C:\\_Workspace\Designs\09 - Product Catalog\02 - Manholes\00 - Parts\00 - Archive\02 - Barrels\02 - Transition Piece Assembly-01.lam



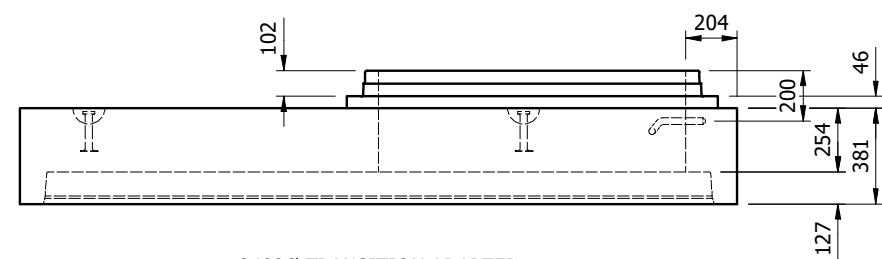
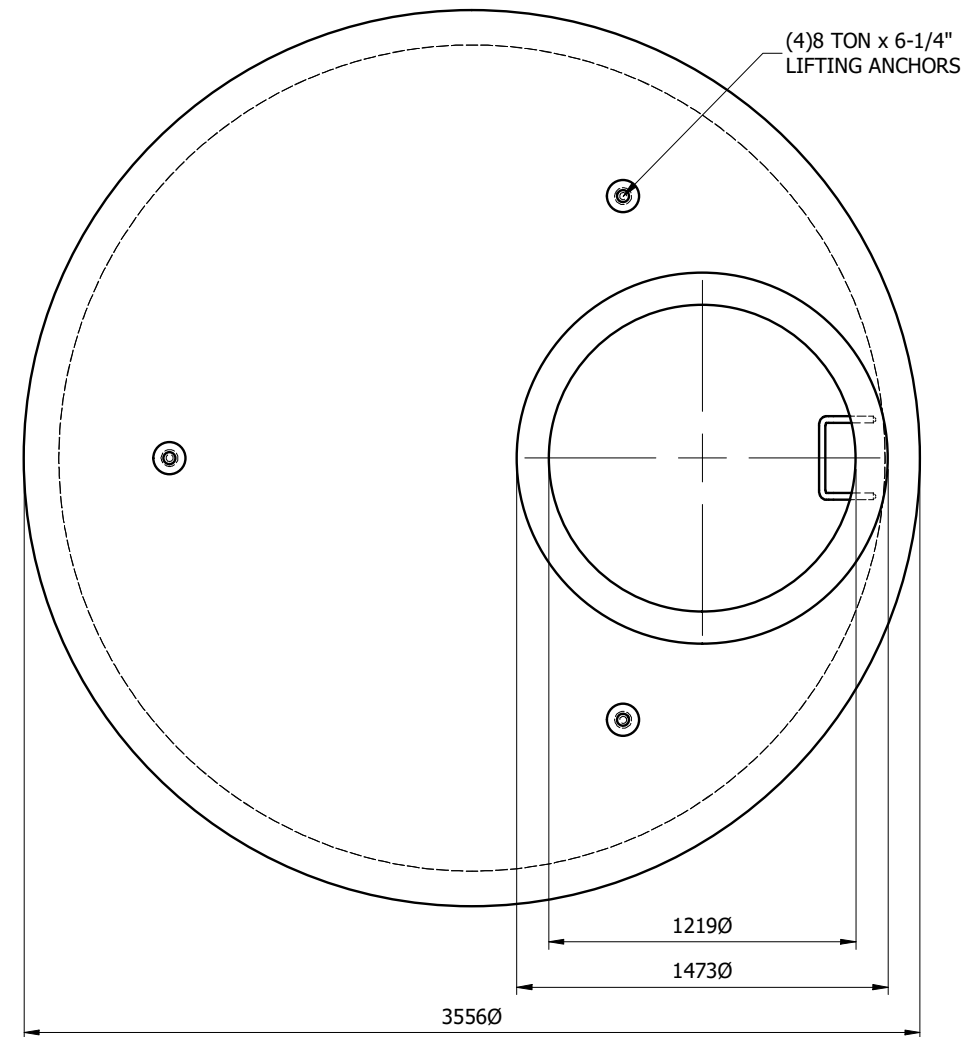
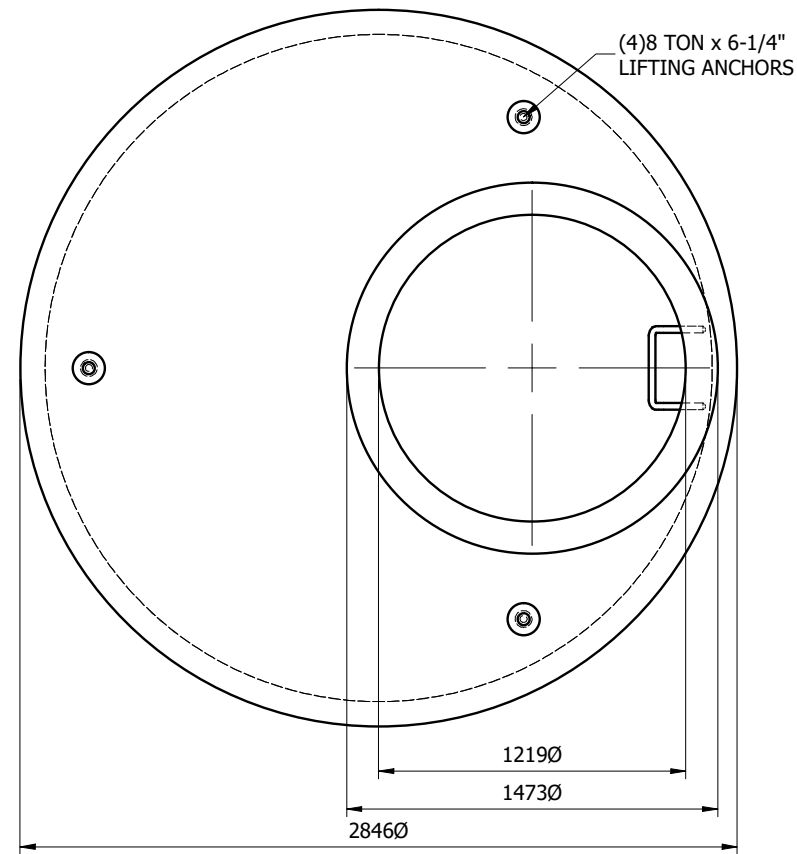

2400Ø TRANSITION ADAPTER

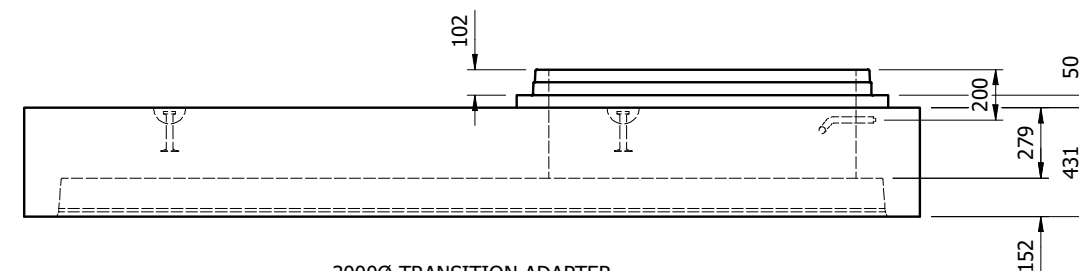

3000Ø TRANSITION ADAPTER

**NOTES:**

- ALL DIMENSIONS ARE IN MILLIMETERS UNLESS OTHERWISE NOTED
- ALL ELEVATIONS ARE IN METERS ABOVE SEA LEVEL

APPROXIMATE WEIGHTS		
PIECE	lb	kg
2400	8,117	3,690
3000	14,445	6,566

# STANDARD TEMPLATE

**PROPRIETARY AND CONFIDENTIAL:**

THE INFORMATION CONTAINED IN THIS DRAWING IS THE SOLE PROPERTY OF PRECON MANUFACTURING LTD. ANY REPRODUCTION IN PART OR AS A WHOLE WITHOUT THE WRITTEN PERMISSION OF PRECON MANUFACTURING LTD. IS PROHIBITED.



© Precon Manufacturing Ltd. www.precon.ca 1-800-661-8020

CONTRACTOR:

PROJECT:

LOCATION:

DESCRIPTION:  
**TRANSITION ADAPTERS**

STRUCTURE NAME:

DRAWN:	CHECKED:
DATE CREATED: 08/26/2020	REQUIRED:
LAST REVISION:	SCALE: 1:30
PROJECT NUMBER:	DRAWING: <b>D0.2</b>

**NOTES:**

- ALL DIMENSIONS ARE IN MILLIMETERS UNLESS OTHERWISE NOTED
- ALL ELEVATIONS ARE IN METERS ABOVE SEA LEVEL

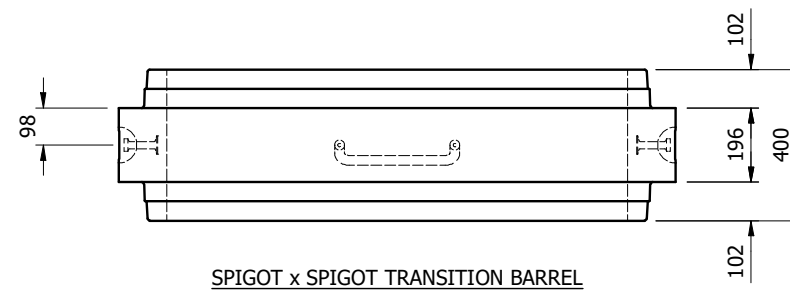
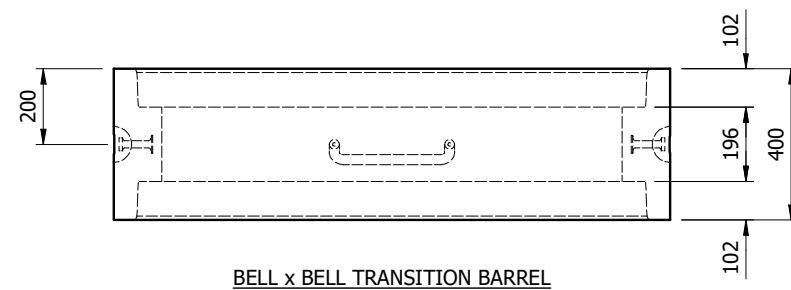
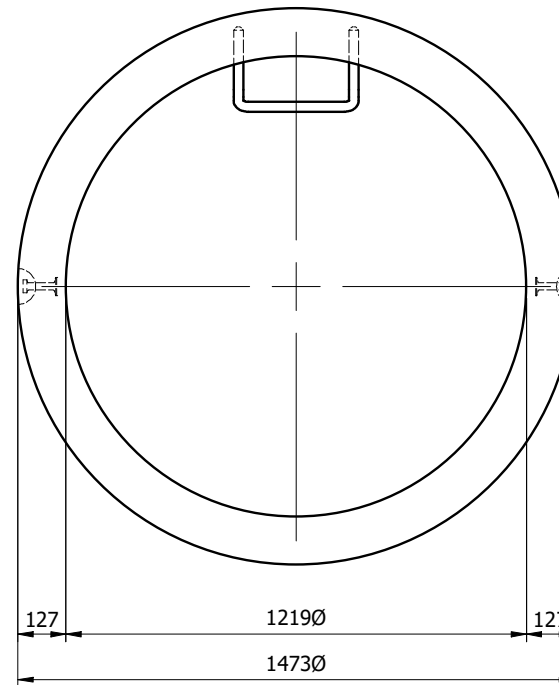
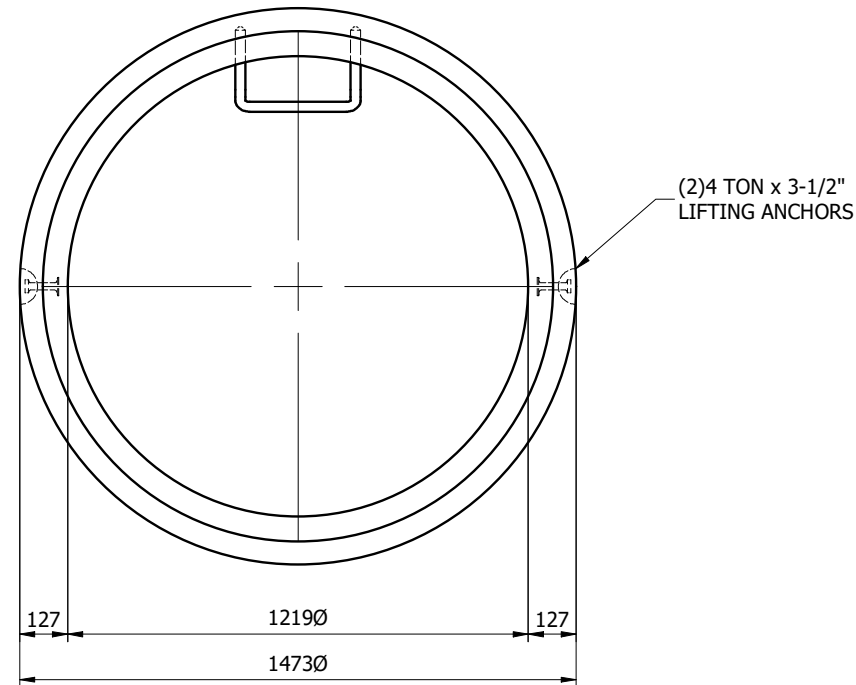

TABLE OF WEIGHTS		
PIECE	lb	kg
BELL	861	391
SPIGOT	801	364

# STANDARD TEMPLATE

**PROPRIETARY AND CONFIDENTIAL:**

THE INFORMATION CONTAINED IN THIS DRAWING IS THE SOLE PROPERTY OF PRECON MANUFACTURING LTD. ANY REPRODUCTION IN PART OR AS A WHOLE WITHOUT THE WRITTEN PERMISSION OF PRECON MANUFACTURING LTD. IS PROHIBITED.



© Precon Manufacturing Ltd. www.precon.ca 1-800-661-8020

CONTRACTOR:

PROJECT:

LOCATION:

DESCRIPTION:  
**1200Ø TRANSITION BARRELS**

STRUCTURE NAME:

DRAWN:	CHECKED:
DATE CREATED: 08/26/2020	REQUIRED:
LAST REVISION:	SCALE: 1:20
PROJECT NUMBER:	DRAWING: <b>D0.1</b>

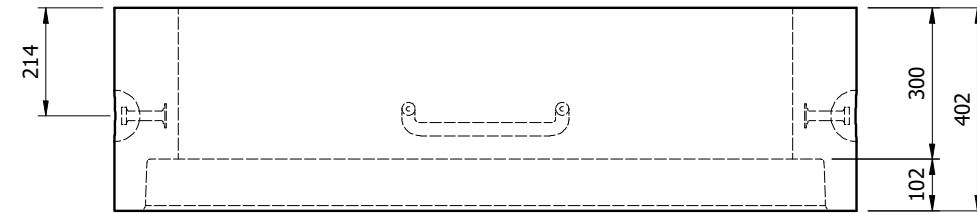
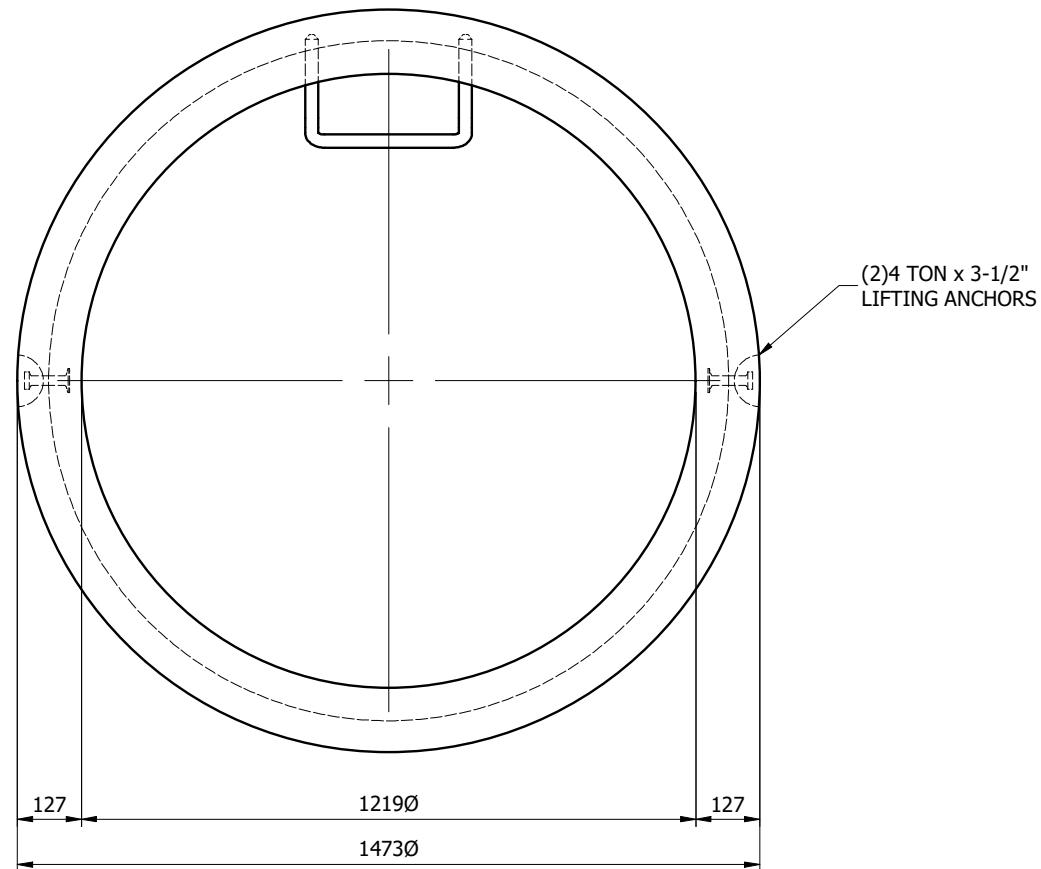

300 FLAT TOP BARREL

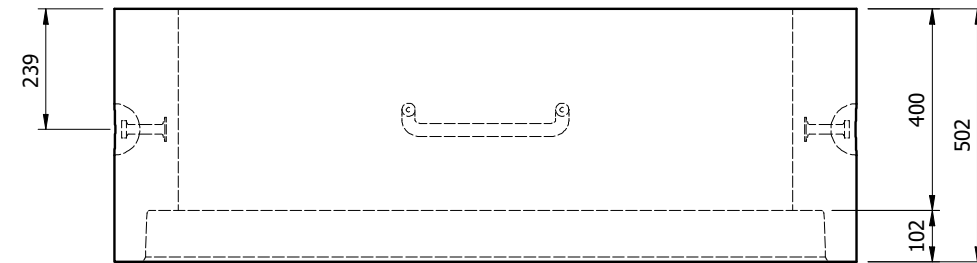

400 FLAT TOP BARREL

**NOTES:**

- ALL DIMENSIONS ARE IN MILLIMETERS UNLESS OTHERWISE NOTED
- ALL ELEVATIONS ARE IN METERS ABOVE SEA LEVEL

TABLE OF WEIGHTS		
PIECE	lb	kg
300	1,006	457
400	1,290	586

# STANDARD TEMPLATE

**PROPRIETARY AND CONFIDENTIAL:**  
 THE INFORMATION CONTAINED IN THIS DRAWING IS THE SOLE PROPERTY OF PRECON MANUFACTURING LTD. ANY REPRODUCTION IN PART OR AS A WHOLE WITHOUT THE WRITTEN PERMISSION OF PRECON MANUFACTURING LTD. IS PROHIBITED.



© Precon Manufacturing Ltd. www.precon.ca 1-800-661-8020

CONTRACTOR:	
PROJECT:	
LOCATION:	
DESCRIPTION: <b>1200Ø FLAT TOP BARRELS</b>	
STRUCTURE NAME:	
DRAWN:	CHECKED:
DATE CREATED: 08/26/2020	REQUIRED:
LAST REVISION:	SCALE: 1:15
PROJECT NUMBER:	DRAWING: <b>D0.1</b>

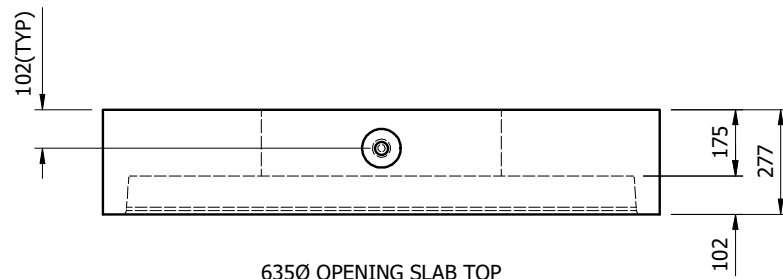
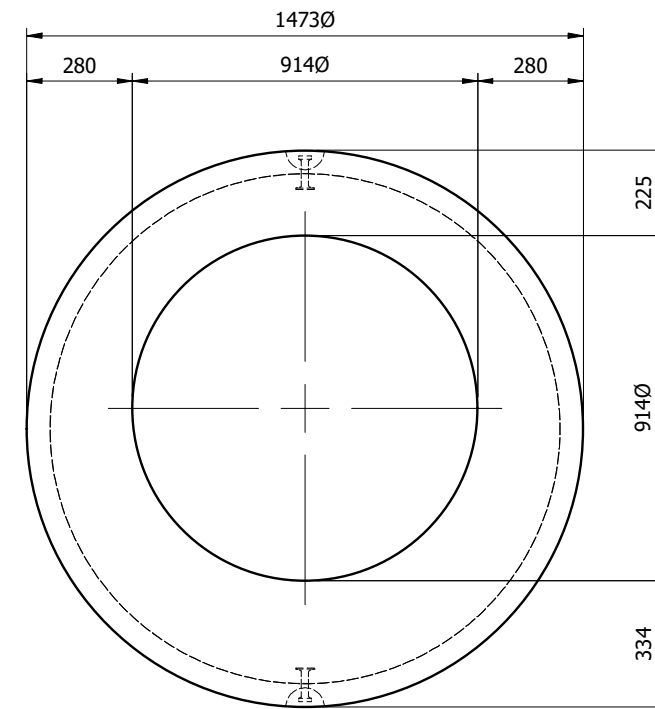
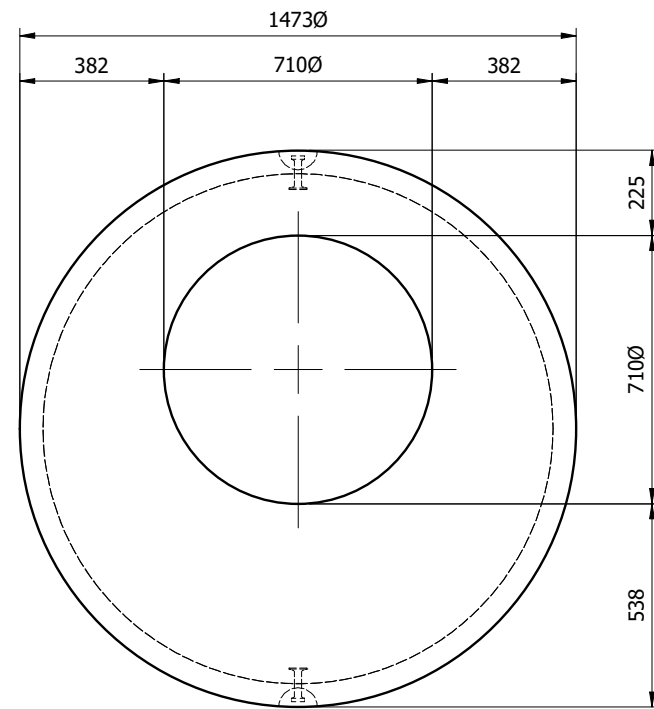
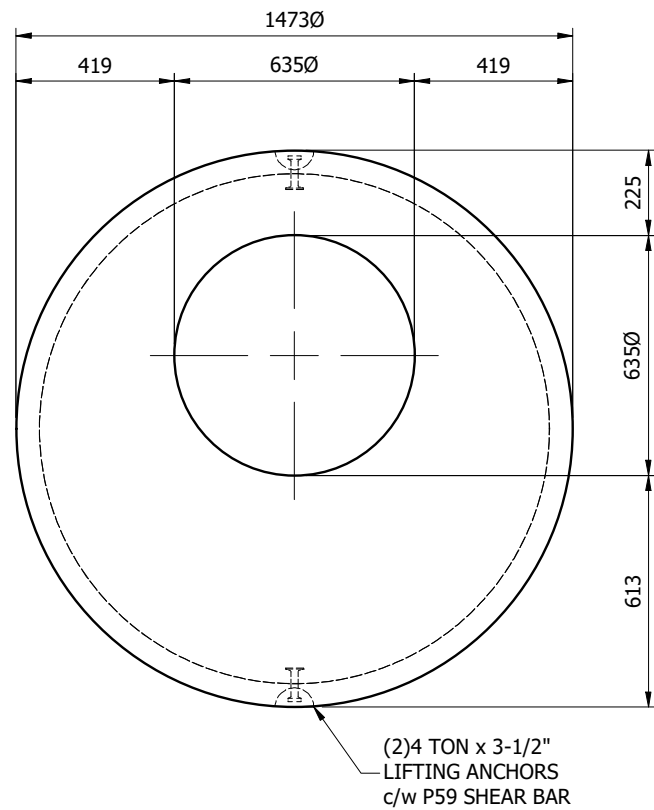

6350 OPENING SLAB TOP

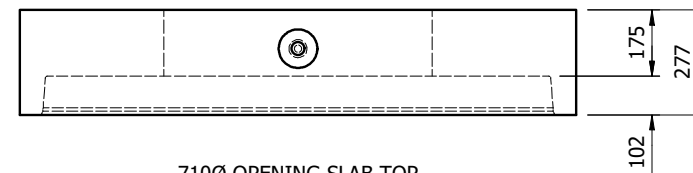

7100 OPENING SLAB TOP

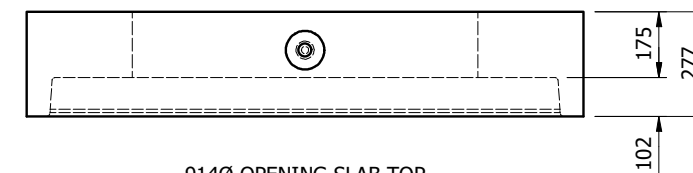

9140 OPENING SLAB TOP

**NOTES:**  
 - ALL DIMENSIONS ARE IN MILLIMETERS UNLESS OTHERWISE NOTED  
 - ALL ELEVATIONS ARE IN METERS ABOVE SEA LEVEL

TABLE OF WEIGHTS		
PIECE	lb	kg
635	1,437	653
710	1,364	620
914	1,122	510

# STANDARD TEMPLATE

**PROPRIETARY AND CONFIDENTIAL:**  
 THE INFORMATION CONTAINED IN THIS DRAWING IS THE SOLE PROPERTY OF PRECON MANUFACTURING LTD. ANY REPRODUCTION IN PART OR AS A WHOLE WITHOUT THE WRITTEN PERMISSION OF PRECON MANUFACTURING LTD. IS PROHIBITED.



© Precon Manufacturing Ltd. www.precon.ca 1-800-661-8020

CONTRACTOR:

PROJECT:

LOCATION:

DESCRIPTION:  
**12000 SLAB TOPS**

STRUCTURE NAME:

DRAWN: CHECKED:

DATE CREATED: 08/26/2020 REQUIRED:

LAST REVISION: SCALE: 1:20

PROJECT NUMBER: DRAWING: **D0.1**

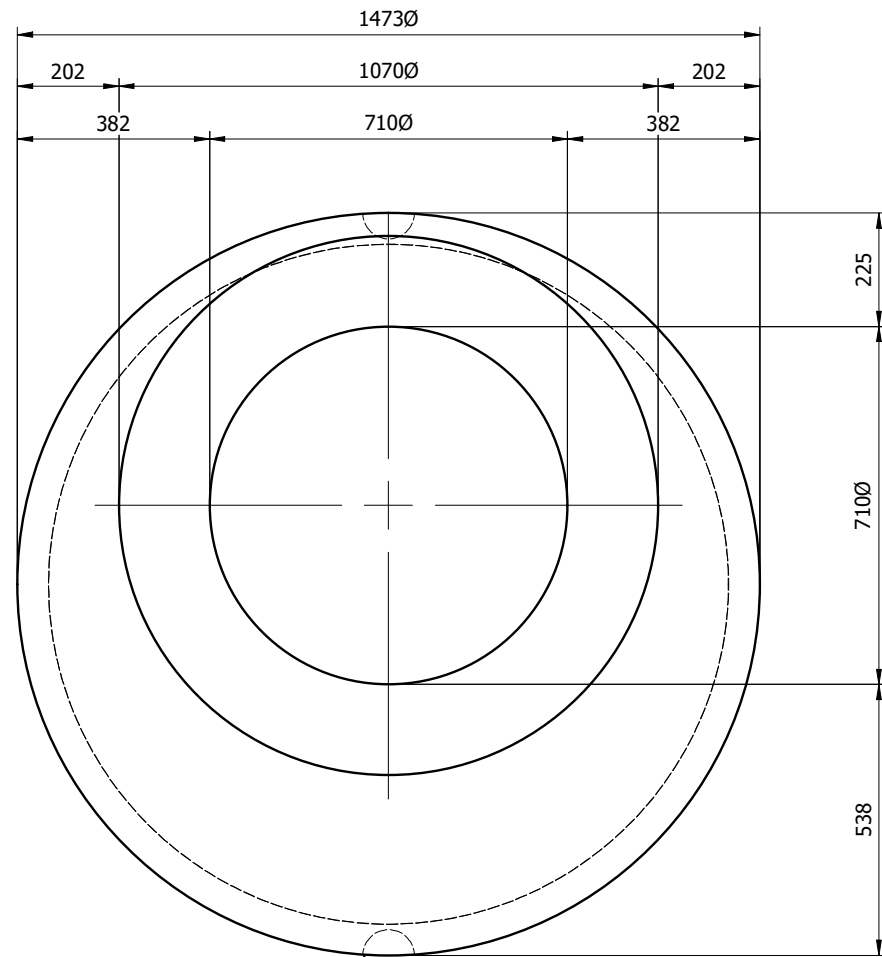

(2)4 TON x 3-1/2"  
LIFTING ANCHORS  
c/w P59 SHEAR BAR

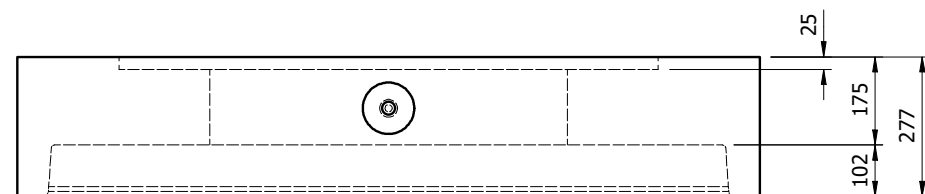
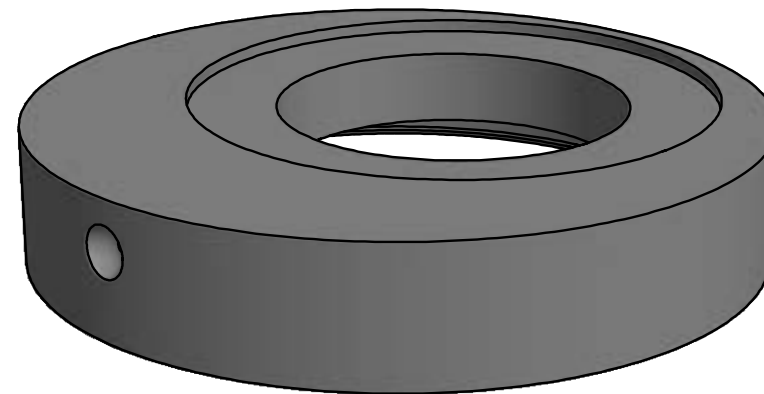

710Ø OPENING SLAB TOP c/w COUNTERSINK

**NOTES:**

- ALL DIMENSIONS ARE IN MILLIMETERS UNLESS OTHERWISE NOTED
- ALL ELEVATIONS ARE IN METERS ABOVE SEA LEVEL

**TABLE OF WEIGHTS**

PIECE	lb	kg
CS 710	1,318	599

# STANDARD TEMPLATE

**PROPRIETARY AND CONFIDENTIAL:**

THE INFORMATION CONTAINED IN THIS DRAWING IS THE SOLE PROPERTY OF PRECON MANUFACTURING LTD. ANY REPRODUCTION IN PART OR AS A WHOLE WITHOUT THE WRITTEN PERMISSION OF PRECON MANUFACTURING LTD. IS PROHIBITED.



© Precon Manufacturing Ltd. www.precon.ca 1-800-661-8020

CONTRACTOR:

PROJECT:

LOCATION:

DESCRIPTION:

**1200Ø CS SLAB TOP**

STRUCTURE NAME:

DRAWN: CHECKED:

DATE CREATED: 08/26/2020 REQUIRED:

LAST REVISION: SCALE: 1:15

PROJECT NUMBER: DRAWING: **D0.1**

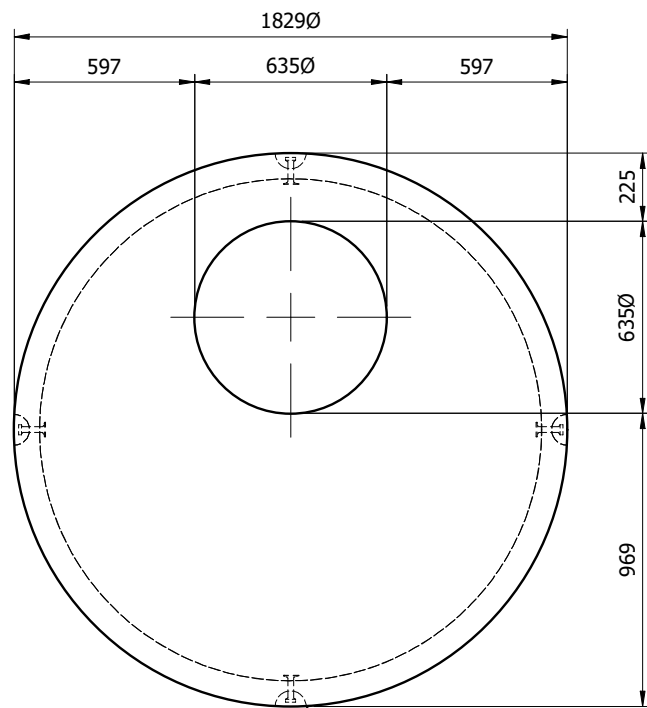

(2) 4 TON x 3-1/2" LIFTING ANCHORS c/w P59 SHEAR BAR

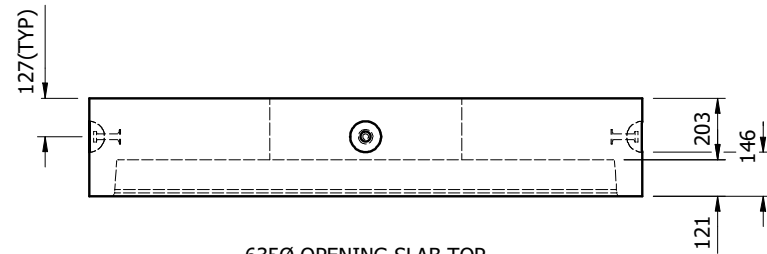
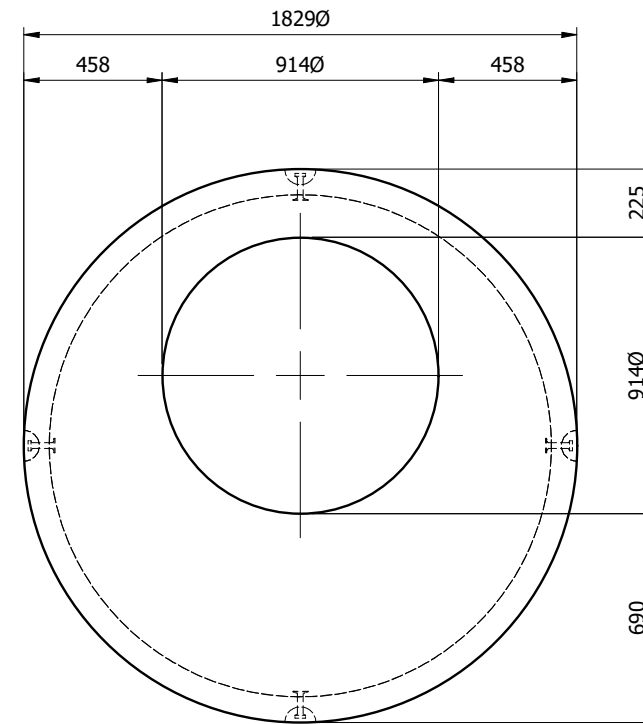
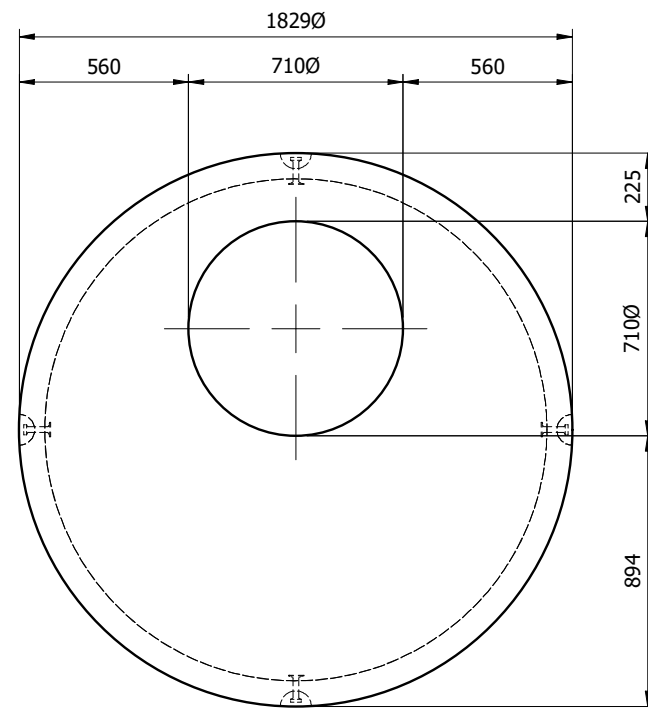

6350 OPENING SLAB TOP

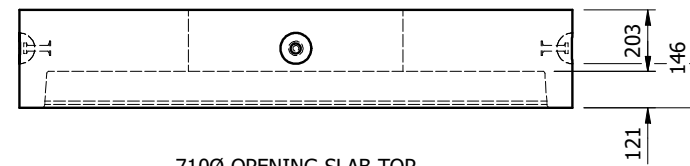

7100 OPENING SLAB TOP



9140 OPENING SLAB TOP

**NOTES:**

- ALL DIMENSIONS ARE IN MILLIMETERS UNLESS OTHERWISE NOTED
- ALL ELEVATIONS ARE IN METERS ABOVE SEA LEVEL

**TABLE OF WEIGHTS**

PIECE	lb	kg
635	2,805	1,275
710	2,720	1,236
914	2,440	1,109

# STANDARD TEMPLATE

**PROPRIETARY AND CONFIDENTIAL:**

THE INFORMATION CONTAINED IN THIS DRAWING IS THE SOLE PROPERTY OF PRECON MANUFACTURING LTD. ANY REPRODUCTION IN PART OR AS A WHOLE WITHOUT THE WRITTEN PERMISSION OF PRECON MANUFACTURING LTD. IS PROHIBITED.



© Precon Manufacturing Ltd. www.precon.ca 1-800-661-8020

CONTRACTOR:

PROJECT:

LOCATION:

DESCRIPTION:  
**1500Ø SLAB TOPS**

STRUCTURE NAME:

DRAWN: CHECKED:

DATE CREATED: 08/26/2020 REQUIRED:

LAST REVISION: SCALE: 1:25

PROJECT NUMBER: DRAWING: **D0.1**

**NOTES:**

- ALL DIMENSIONS ARE IN MILLIMETERS UNLESS OTHERWISE NOTED
- ALL ELEVATIONS ARE IN METERS ABOVE SEA LEVEL

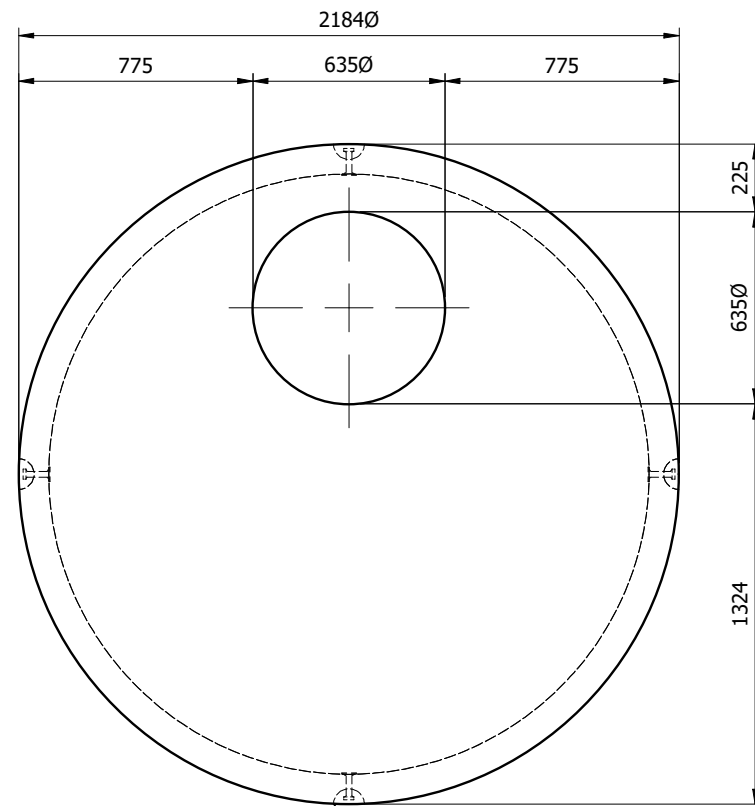

(4) 4 TON x 3-1/2" LIFTING ANCHORS c/w P59 SHEAR BAR

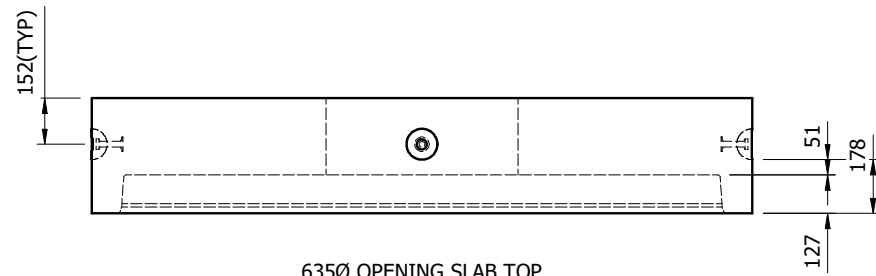
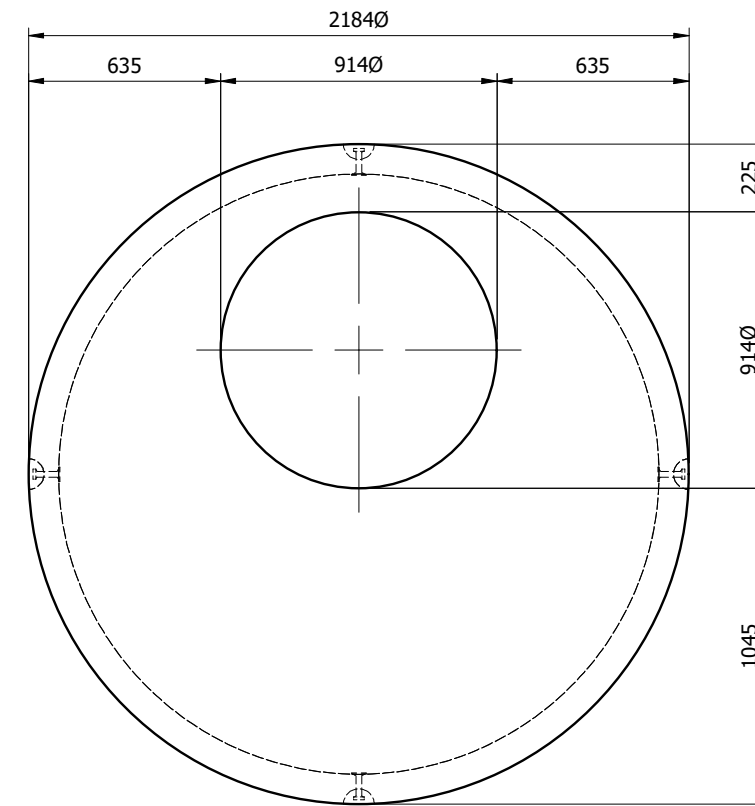
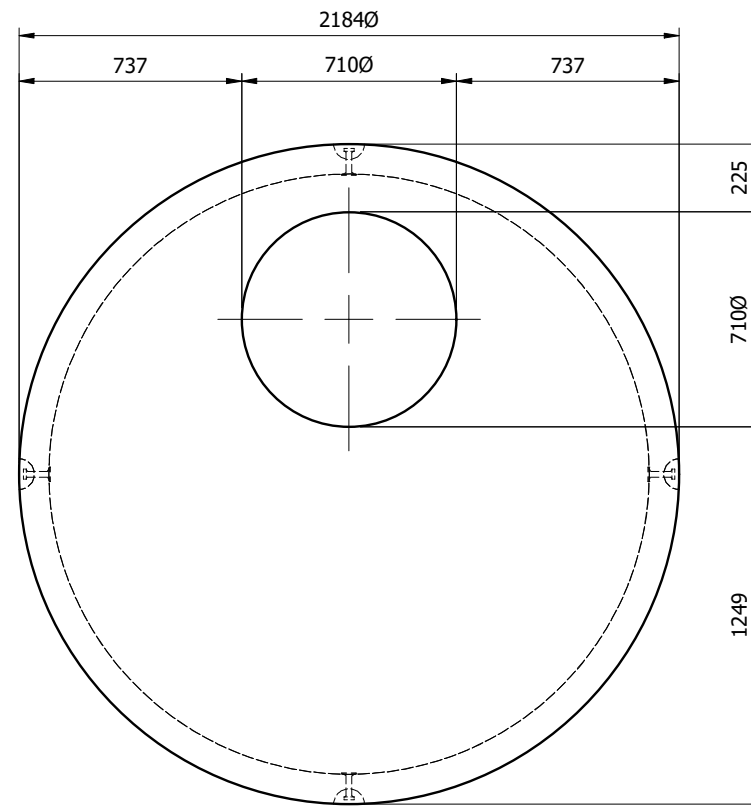

6350 OPENING SLAB TOP

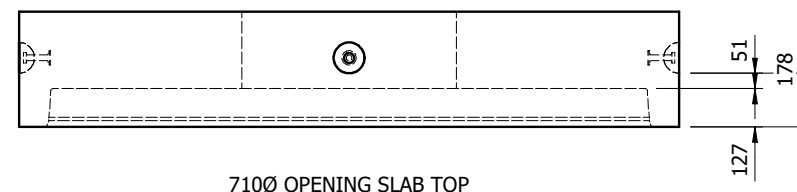

7100 OPENING SLAB TOP

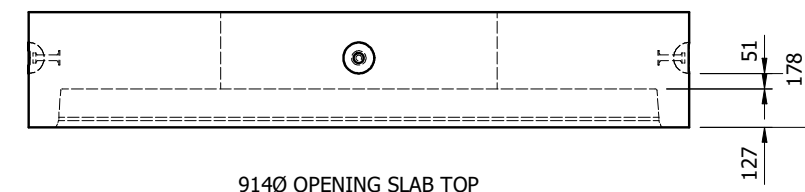

9140 OPENING SLAB TOP

TABLE OF WEIGHTS		
PIECE	lb	kg
635	5,060	2,300
710	4,954	2,252
914	4,604	2,093

# STANDARD TEMPLATE

**PROPRIETARY AND CONFIDENTIAL:**

THE INFORMATION CONTAINED IN THIS DRAWING IS THE SOLE PROPERTY OF PRECON MANUFACTURING LTD. ANY REPRODUCTION IN PART OR AS A WHOLE WITHOUT THE WRITTEN PERMISSION OF PRECON MANUFACTURING LTD. IS PROHIBITED.



© Precon Manufacturing Ltd. www.precon.ca 1-800-661-8020

CONTRACTOR:

PROJECT:

LOCATION:

DESCRIPTION:  
**1800Ø SLAB TOPS**

STRUCTURE NAME:

DRAWN: CHECKED:

DATE CREATED: 08/26/2020 REQUIRED:

LAST REVISION: SCALE: 1:25

PROJECT NUMBER: DRAWING: **D0.1**

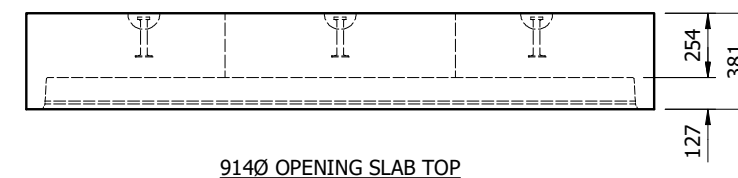
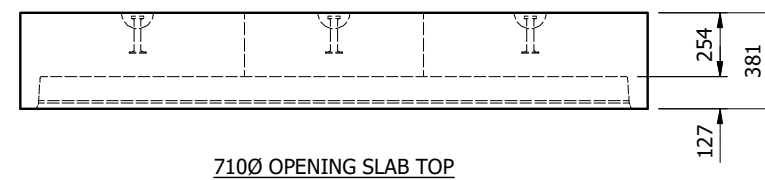
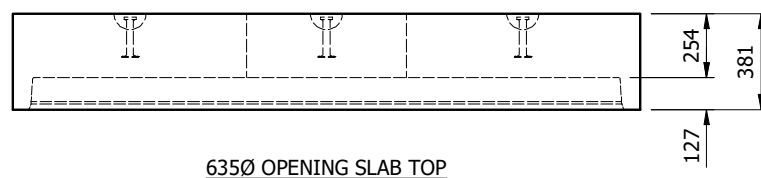
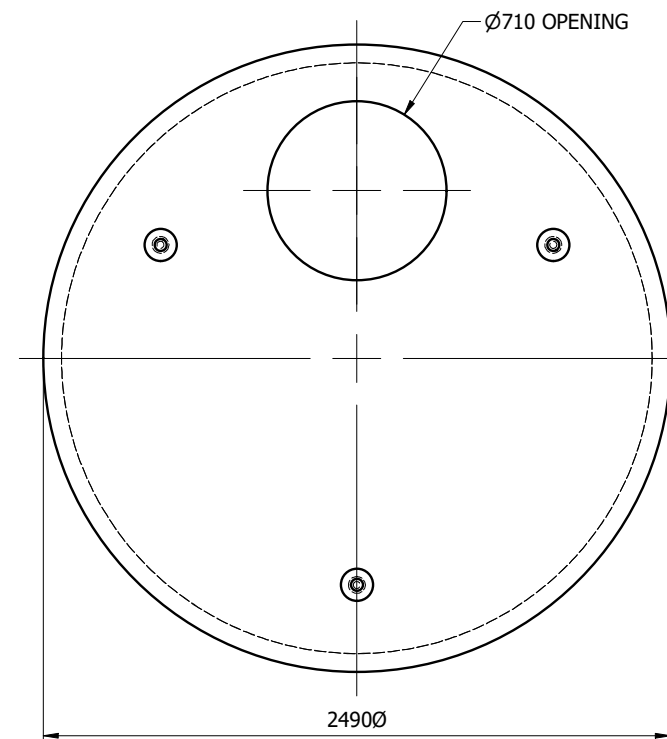
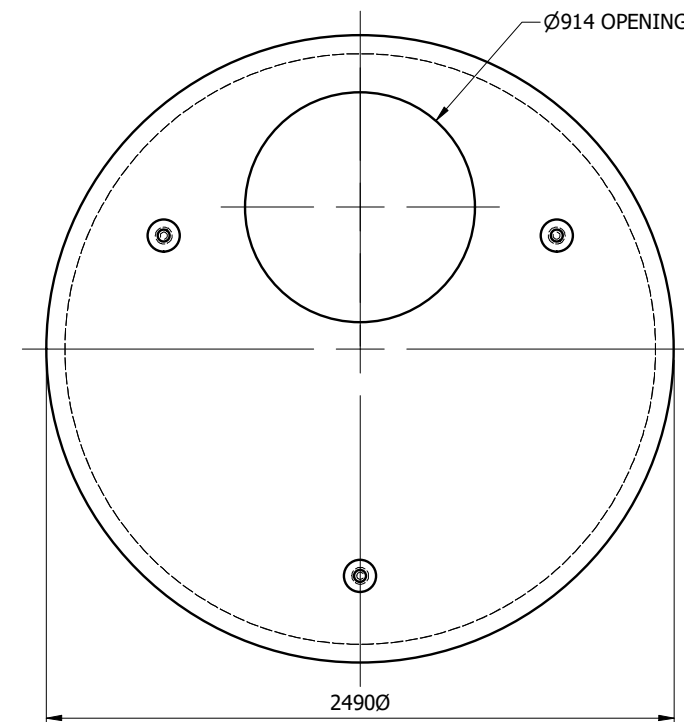
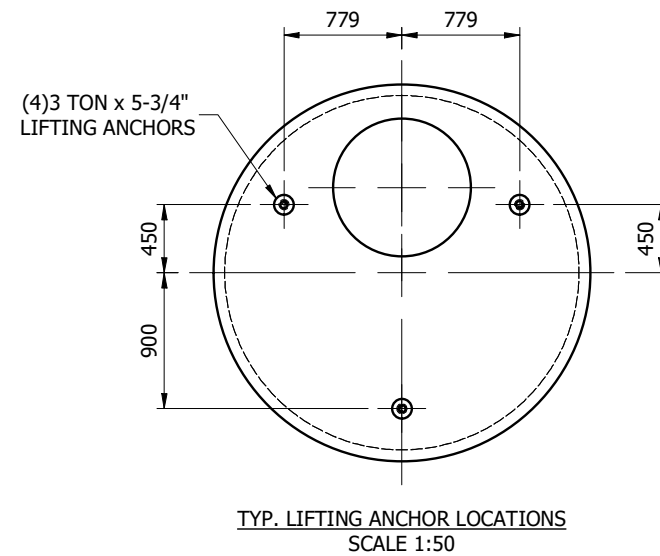
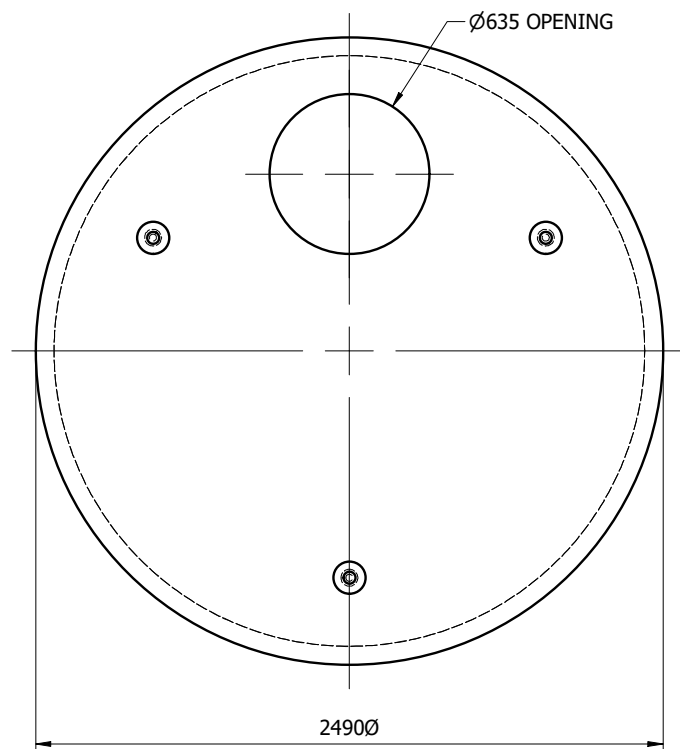

**NOTES:**

- ALL DIMENSIONS ARE IN MILLIMETERS UNLESS OTHERWISE NOTED
- ALL ELEVATIONS ARE IN METERS ABOVE SEA LEVEL

APPROXIMATE WEIGHTS			
PIECE	lb	kg	BURY DEPTH
635	6,506	2,957	-
710	6,400	2,909	-
914	6,049	2,750	-

# STANDARD TEMPLATE

**PROPRIETARY AND CONFIDENTIAL:**

THE INFORMATION CONTAINED IN THIS DRAWING IS THE SOLE PROPERTY OF PRECON MANUFACTURING LTD. ANY REPRODUCTION IN PART OR AS A WHOLE WITHOUT THE WRITTEN PERMISSION OF PRECON MANUFACTURING LTD. IS PROHIBITED.



© Precon Manufacturing Ltd. www.precon.ca 1-800-661-8020

CONTRACTOR:  
**PRECON**

PROJECT:  
-

LOCATION:  
-

DESCRIPTION:  
**2138Ø SLAB TOPS**

STRUCTURE NAME:

DRAWN: R.GRANT CHECKED:

DATE CREATED: 10/25/2021 REQUIRED:

LAST REVISION: SCALE: 1:30

PROJECT NUMBER: - DRAWING: **D0.1**



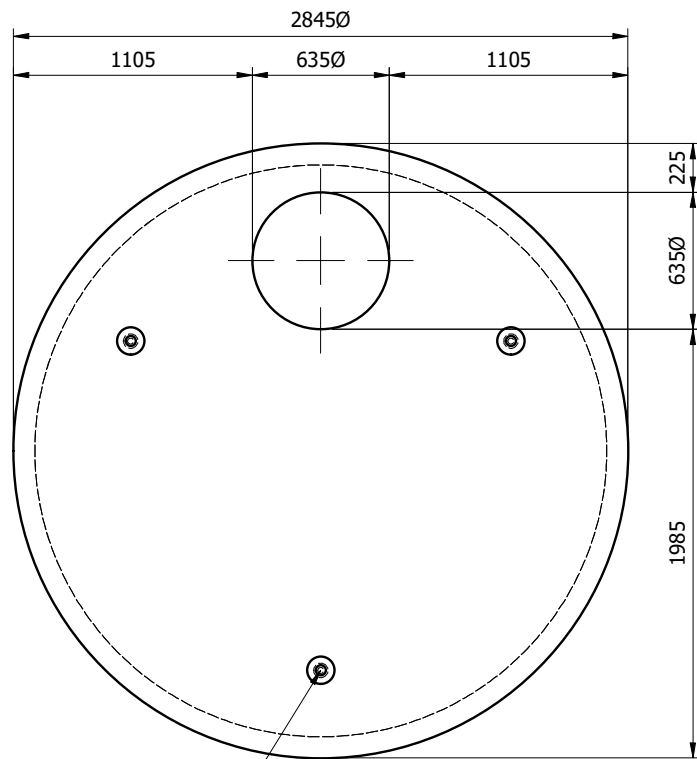

(4) 8 TON x 6-1/4" LIFTING ANCHORS

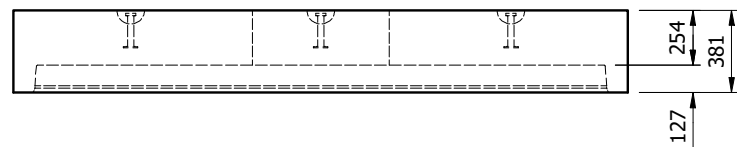

6350 OPENING SLAB TOP

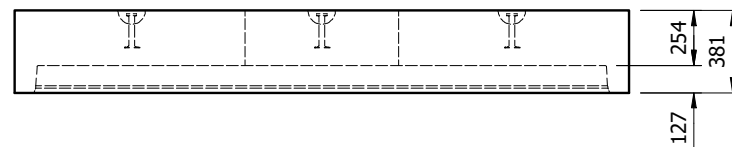
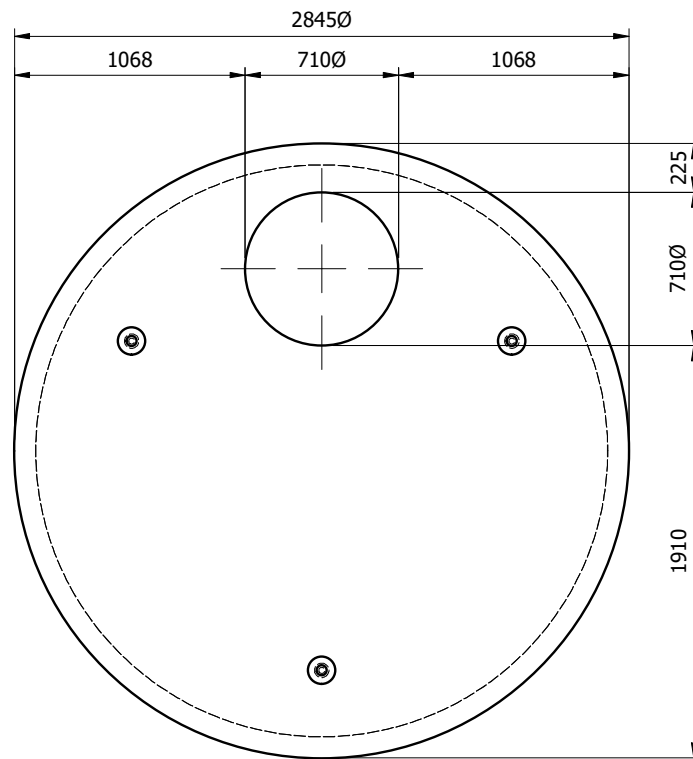

7100 OPENING SLAB TOP

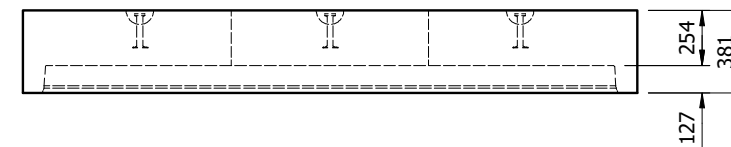
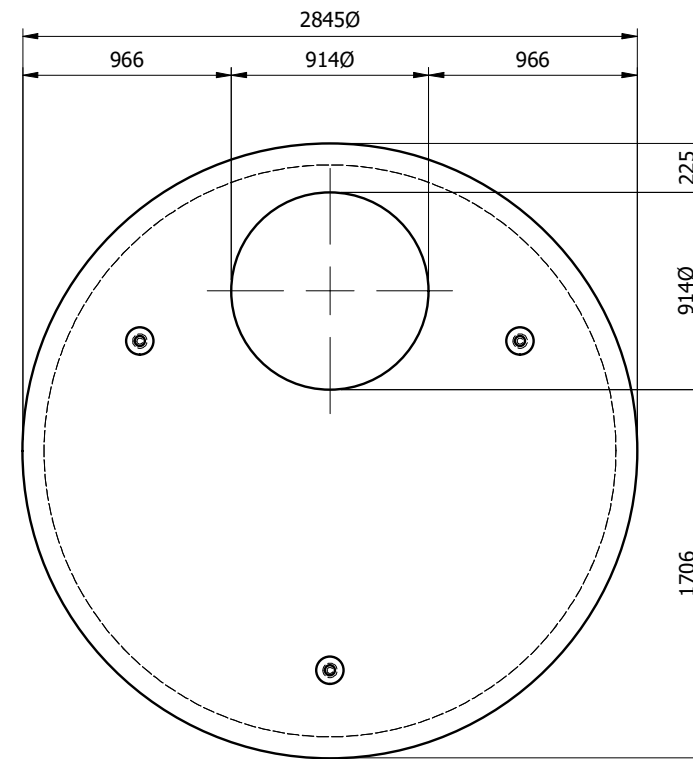

9140 OPENING SLAB TOP

**NOTES:**

- ALL DIMENSIONS ARE IN MILLIMETERS UNLESS OTHERWISE NOTED
- ALL ELEVATIONS ARE IN METERS ABOVE SEA LEVEL

**TABLE OF WEIGHTS**

PIECE	lb	kg
635	8,719	3,963
710	8,612	3,915
914	8,262	3,755

# STANDARD TEMPLATE

**PROPRIETARY AND CONFIDENTIAL:**

THE INFORMATION CONTAINED IN THIS DRAWING IS THE SOLE PROPERTY OF PRECON MANUFACTURING LTD. ANY REPRODUCTION IN PART OR AS A WHOLE WITHOUT THE WRITTEN PERMISSION OF PRECON MANUFACTURING LTD. IS PROHIBITED.



© Precon Manufacturing Ltd. www.precon.ca 1-800-661-8020

CONTRACTOR:

PROJECT:

LOCATION:

DESCRIPTION:  
**2400Ø SLAB TOPS**

STRUCTURE NAME:

DRAWN: CHECKED:

DATE CREATED: 08/26/2020 REQUIRED:

LAST REVISION: SCALE: 1:35

PROJECT NUMBER: DRAWING: **D0.1**

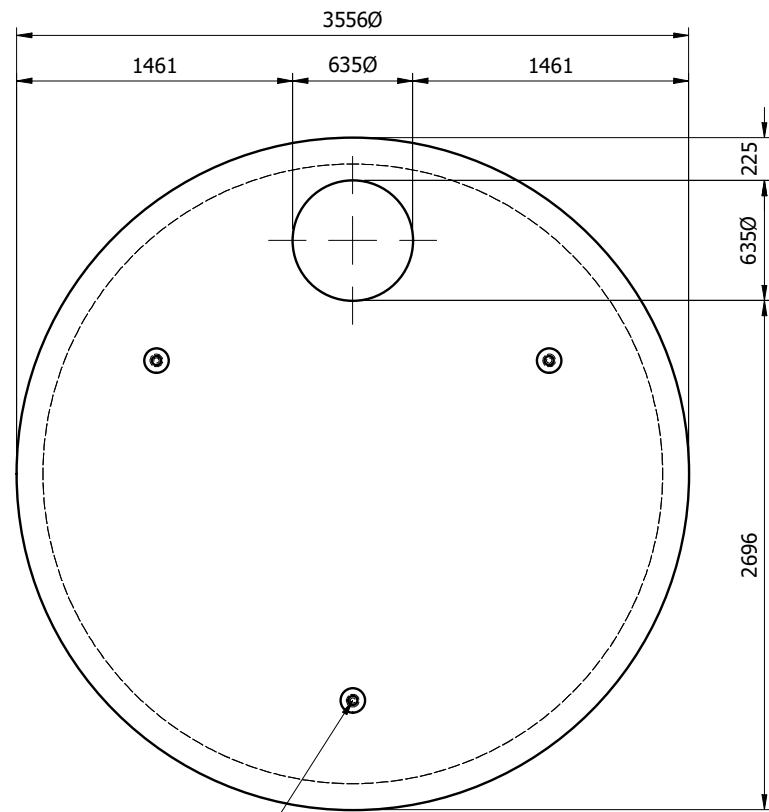

(4) 8 TON x 6-1/4" LIFTING ANCHORS

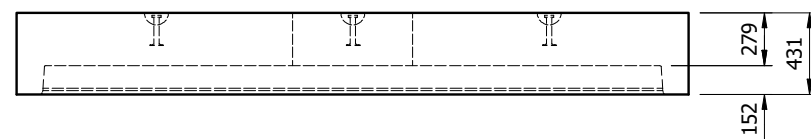
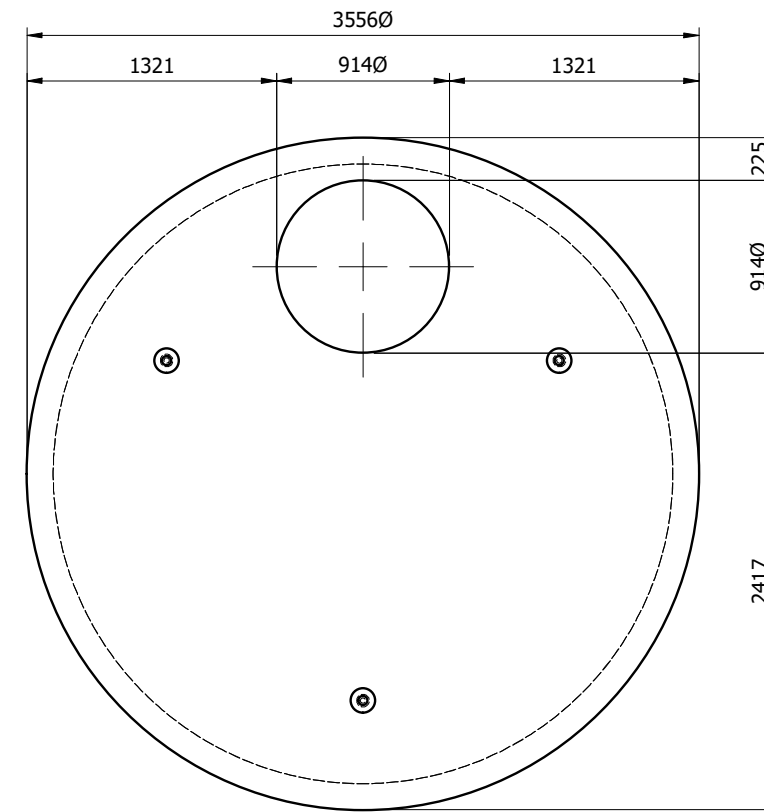
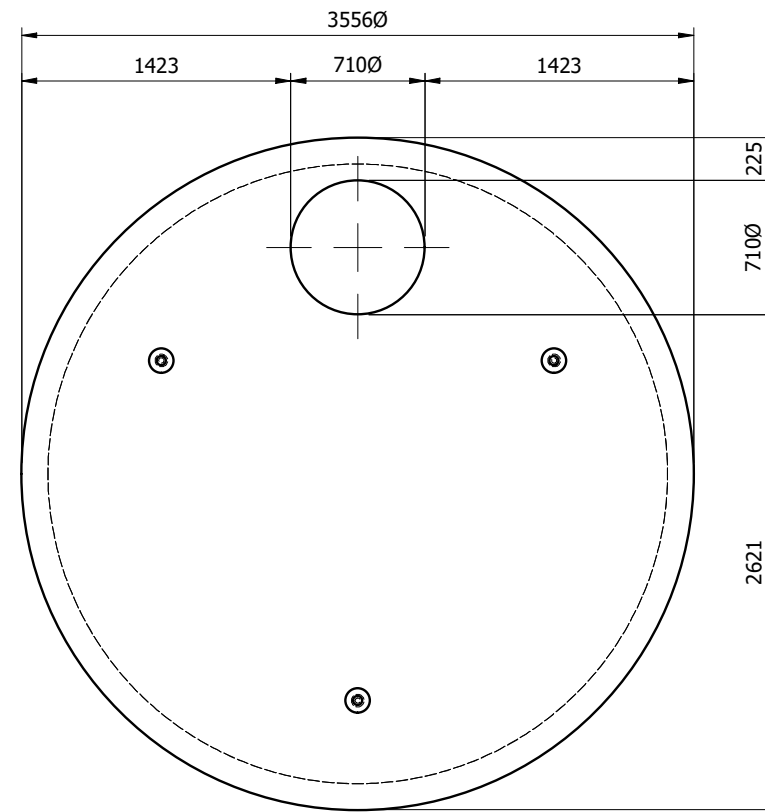

6350 Ø OPENING SLAB TOP

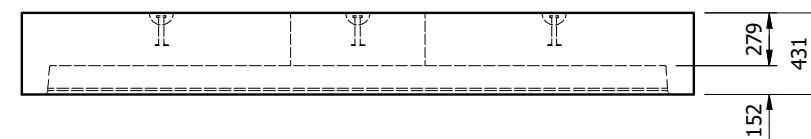

7100 Ø OPENING SLAB TOP

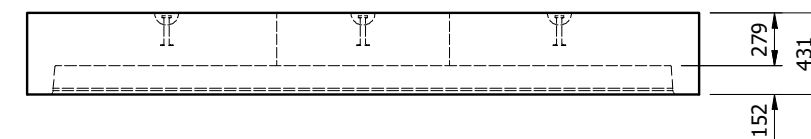

9140 Ø OPENING SLAB TOP

**NOTES:**

- ALL DIMENSIONS ARE IN MILLIMETERS UNLESS OTHERWISE NOTED
- ALL ELEVATIONS ARE IN METERS ABOVE SEA LEVEL

APPROXIMATE WEIGHTS		
PIECE	lb	kg
635	15,432	7,015
710	15,315	6,961
914	14,931	6,787

# STANDARD TEMPLATE

**PROPRIETARY AND CONFIDENTIAL:**

THE INFORMATION CONTAINED IN THIS DRAWING IS THE SOLE PROPERTY OF PRECON MANUFACTURING LTD. ANY REPRODUCTION IN PART OR AS A WHOLE WITHOUT THE WRITTEN PERMISSION OF PRECON MANUFACTURING LTD. IS PROHIBITED.



© Precon Manufacturing Ltd. www.precon.ca 1-800-661-8020

CONTRACTOR:

PROJECT:

LOCATION:

DESCRIPTION:  
**3000 Ø SLAB TOPS**

STRUCTURE NAME:

DRAWN: CHECKED:

DATE CREATED: 08/26/2020 REQUIRED:

LAST REVISION: SCALE: 1:40

PROJECT NUMBER: DRAWING: **D0.1**

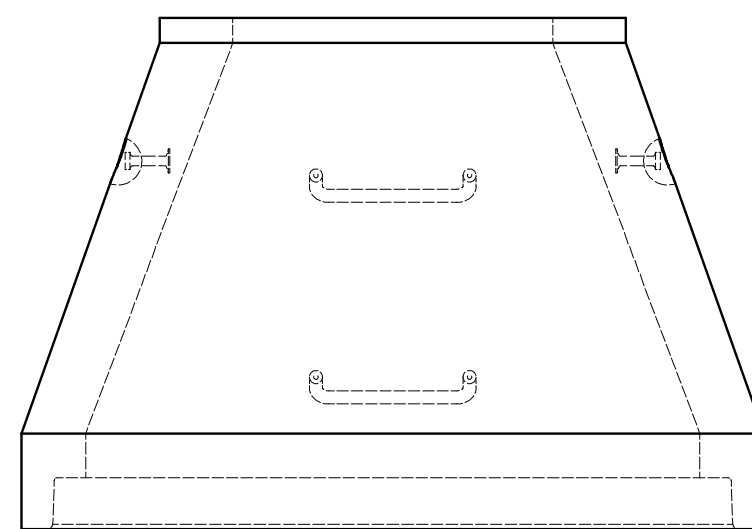
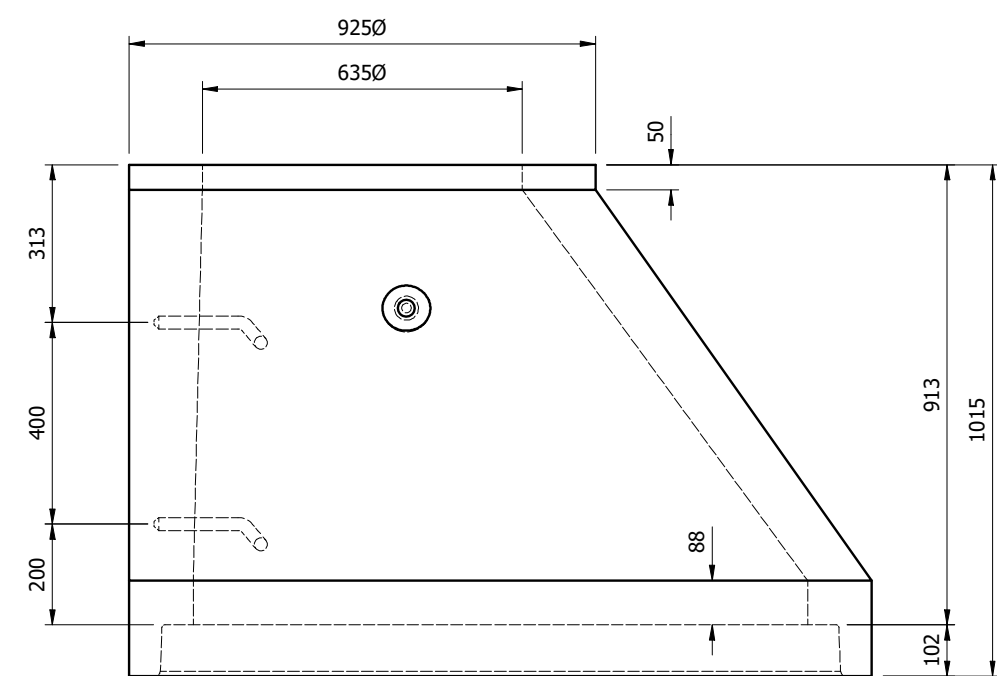
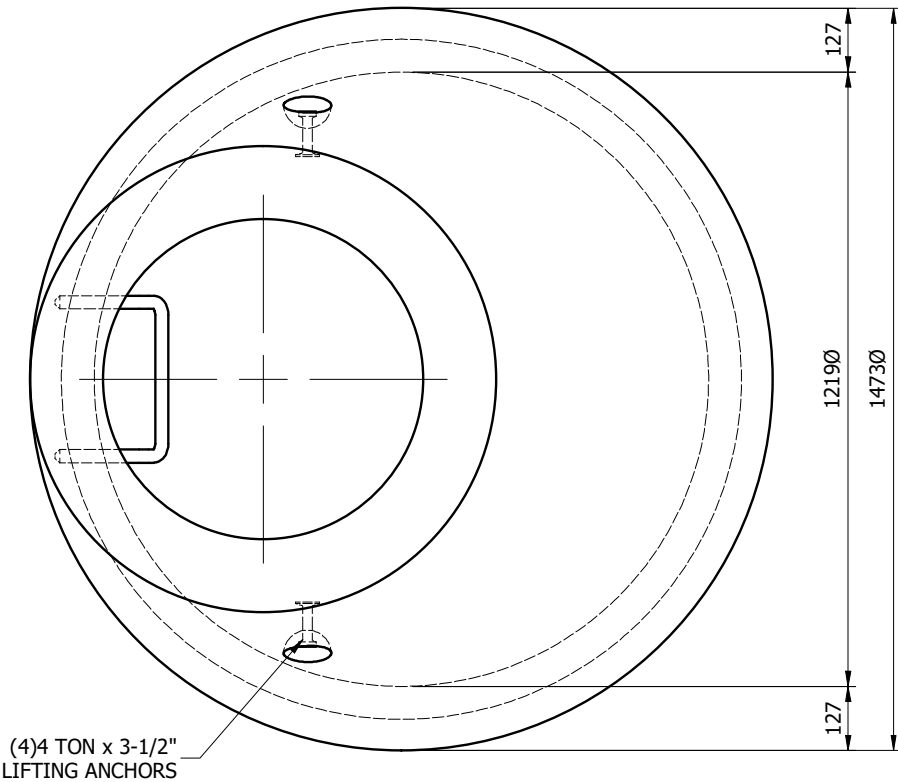

**NOTES:**  
 - ALL DIMENSIONS ARE IN MILLIMETERS UNLESS OTHERWISE NOTED  
 - ALL ELEVATIONS ARE IN METERS ABOVE SEA LEVEL

TABLE OF WEIGHTS		
PIECE	lb	kg
CONICAL	2,353	1,070

# STANDARD TEMPLATE

**PROPRIETARY AND CONFIDENTIAL:**  
 THE INFORMATION CONTAINED IN THIS DRAWING IS THE SOLE PROPERTY OF PRECON MANUFACTURING LTD. ANY REPRODUCTION IN PART OR AS A WHOLE WITHOUT THE WRITTEN PERMISSION OF PRECON MANUFACTURING LTD. IS PROHIBITED.

**PRECON**  
 © Precon Manufacturing Ltd. www.precon.ca 1-800-661-8020

CONTRACTOR:

PROJECT:

LOCATION:

DESCRIPTION:  
**CONICAL TOP**

STRUCTURE NAME:

DRAWN:	CHECKED:
DATE CREATED: 08/26/2020	REQUIRED:
LAST REVISION:	SCALE: 1:15
PROJECT NUMBER:	DRAWING: <b>D0.1</b>

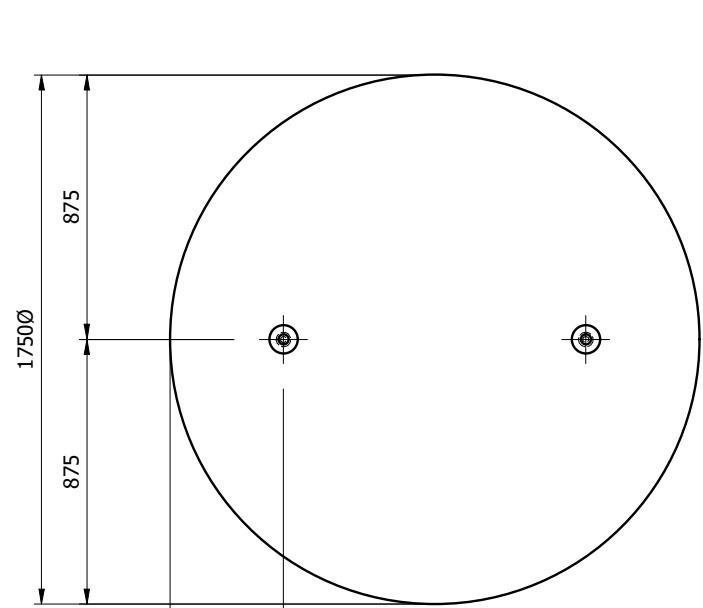

375 (TYP)

(2) 4 TON x 3-1/2" LIFTING ANCHORS (TYP.)

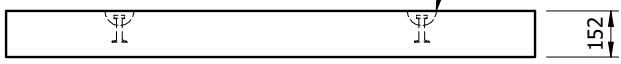

NO OPENING CBMH TOP

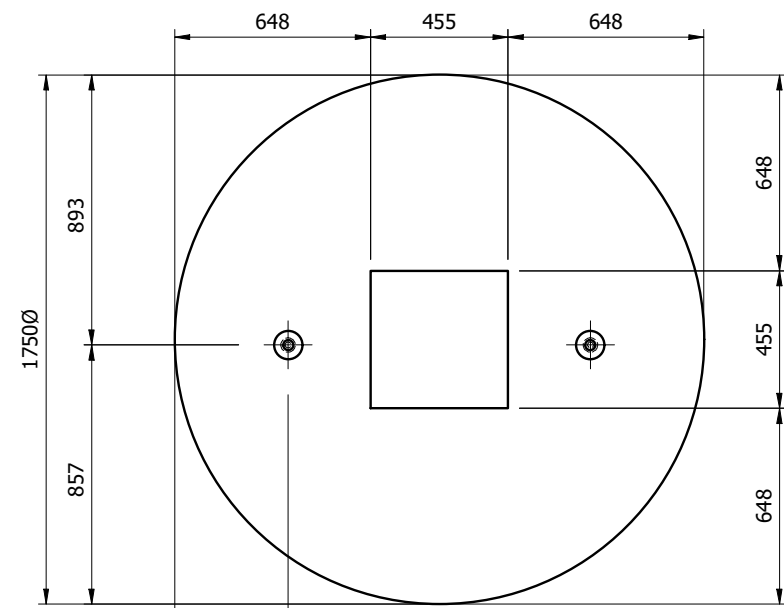

375 (TYP)

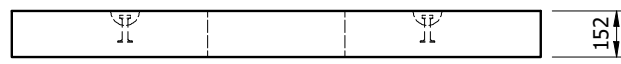

TYPE E OPENING CBMH TOP

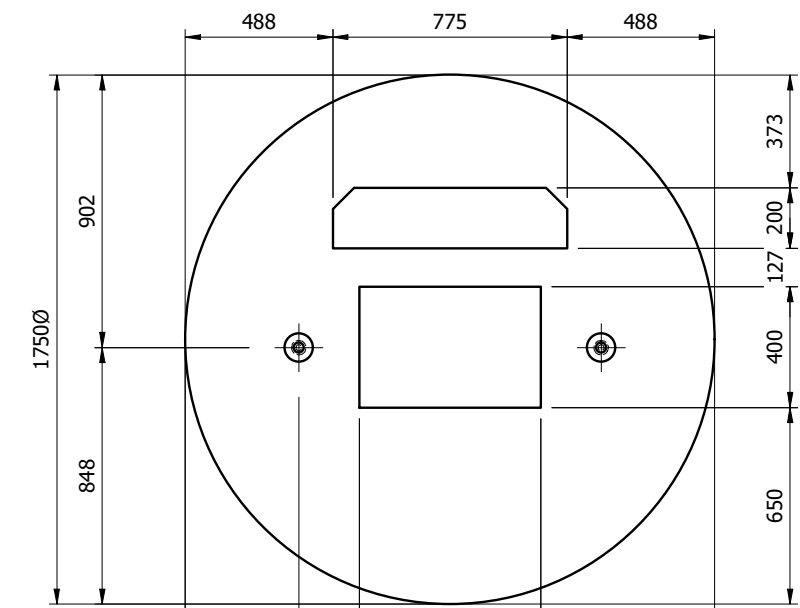

375 (TYP)

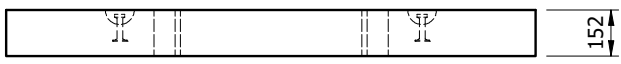

TYPE K1 OPENING CBMH TOP

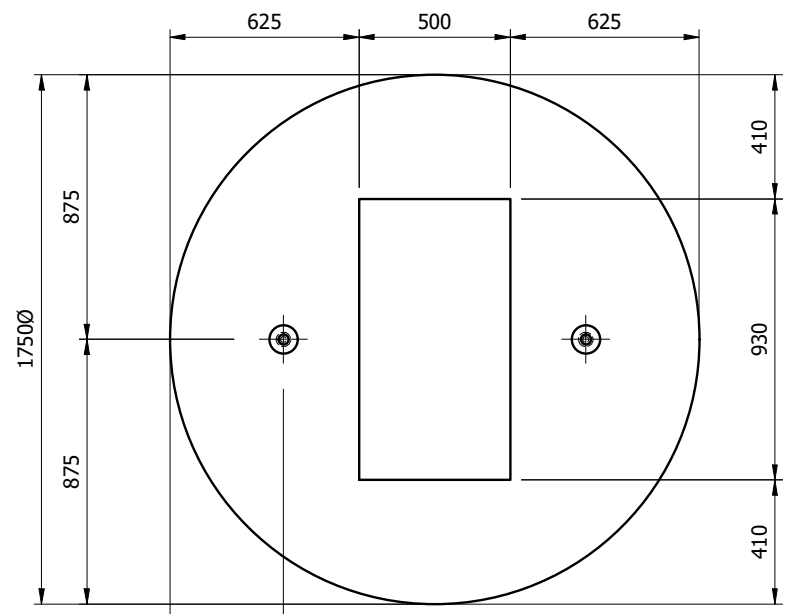

375 (TYP)

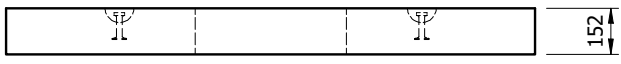

TYPE K2 OPENING CBMH TOP

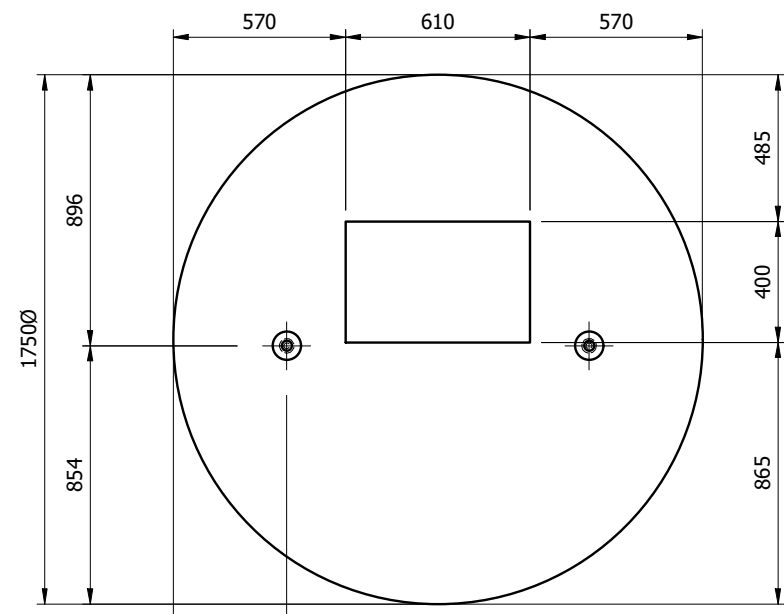

375 (TYP)

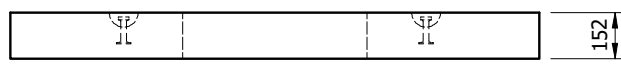

TYPE K3 OPENING CBMH TOP

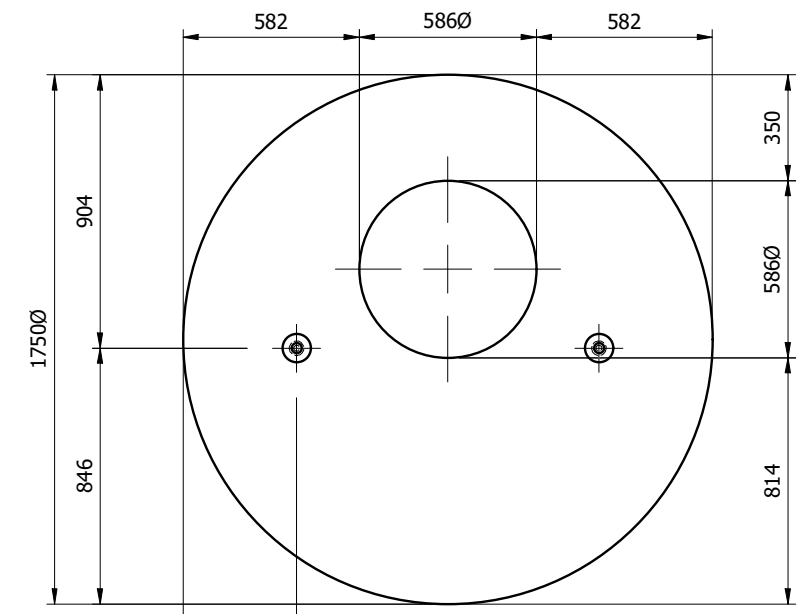

375 (TYP)

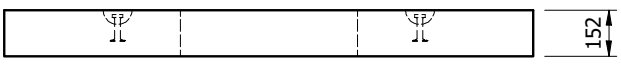

TYPE K4 OPENING CBMH TOP

**NOTES:**

- ALL DIMENSIONS ARE IN MILLIMETERS UNLESS OTHERWISE NOTED
- ALL ELEVATIONS ARE IN METERS ABOVE SEA LEVEL

TABLE OF WEIGHTS		
PIECE	lb	kg
NONE	1,936	880
TYPE E	1,769	804
TYPE K1	1,622	737
TYPE K2	1,561	710
TYPE K3	1,739	790
TYPE K4	1,719	781

# STANDARD TEMPLATE

**PROPRIETARY AND CONFIDENTIAL:**  
 THE INFORMATION CONTAINED IN THIS DRAWING IS THE SOLE PROPERTY OF PRECON MANUFACTURING LTD. ANY REPRODUCTION IN PART OR AS A WHOLE WITHOUT THE WRITTEN PERMISSION OF PRECON MANUFACTURING LTD. IS PROHIBITED.



CONTRACTOR:	
PROJECT:	
LOCATION:	
DESCRIPTION: <b>CBMH TOPS</b>	
STRUCTURE NAME:	
DRAWN:	CHECKED:
DATE CREATED: 08/26/2020	REQUIRED:
LAST REVISION:	SCALE: 1:25
PROJECT NUMBER:	DRAWING: <b>D0.1</b>

**NOTES:**

- CONCRETE - TYPE HS CEMENT - 30 MPa AT 28 DAYS
- AIR ENTRAINMENT - 5% TO 8% - 20mm MAX. AGGREGATE SIZE
- REINFORCEMENT - 400 MPa MINIMUM YIELD STRENGTH  
- 25mm COVER
- SEALANT - 25x25 CONSEAL No. 202
- ALL DIMENSIONS ARE IN MILLIMETERS UNLESS OTHERWISE NOTED
- ALL ELEVATIONS ARE IN METERS ABOVE SEA LEVEL

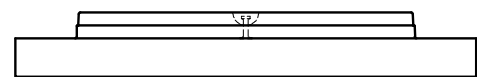
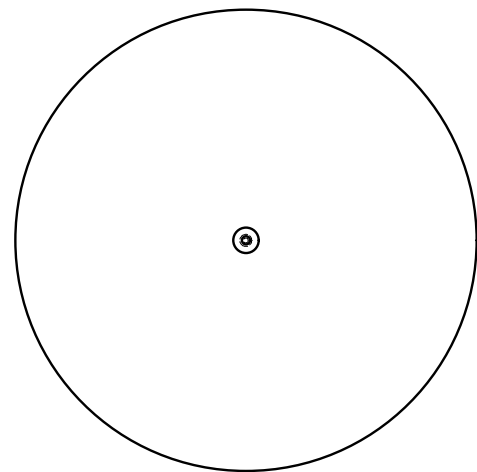

1200Ø HYDROGUARD/ANTI-FLOTATION SLAB BASE

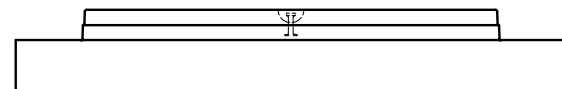
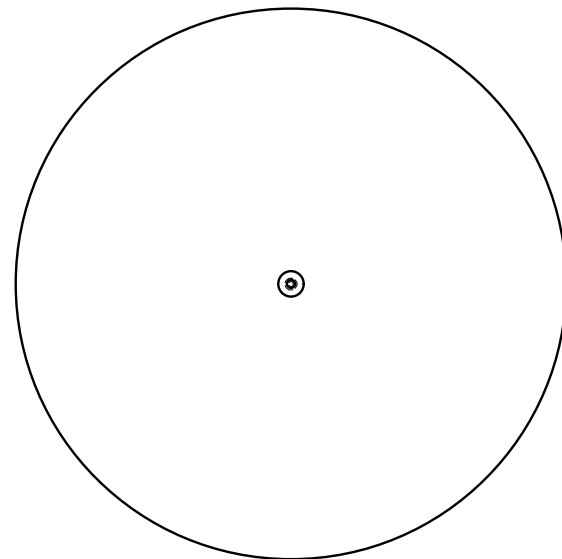

1500Ø HYDROGUARD/ANTI-FLOTATION SLAB BASE

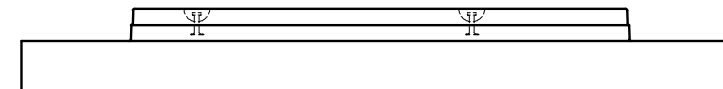
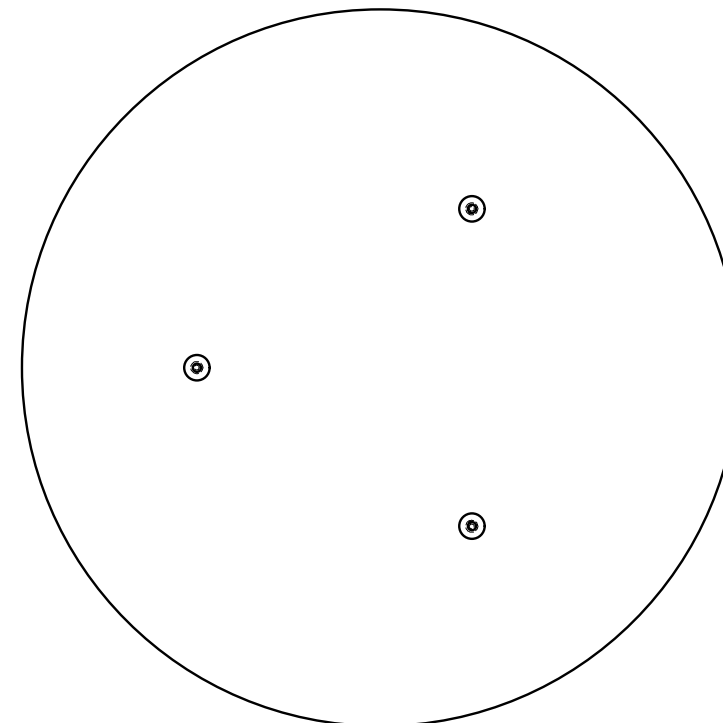

1800Ø HYDROGUARD/ANTI-FLOTATION SLAB BASE

**TABLE OF WEIGHTS**

PIECE	lb	kg	BURY DEPTH
1200	2,914	1,325	-
1500	5,477	2,489	-
1800	8,921	4,055	-

**PROPRIETARY AND CONFIDENTIAL:**

THE INFORMATION CONTAINED IN THIS DRAWING IS THE SOLE PROPERTY OF PRECON MANUFACTURING LTD. ANY REPRODUCTION IN PART OR AS A WHOLE WITHOUT THE WRITTEN PERMISSION OF PRECON MANUFACTURING LTD. IS PROHIBITED.



© Precon Manufacturing Ltd. www.precon.ca 1-800-661-8020

CONTRACTOR:

PROJECT:

LOCATION:

DESCRIPTION:  
**HYDROGUARD/ANTI-FLOTATION SLAB BASE**

STRUCTURE NAME:  
-

DRAWN: CHECKED:

DATE CREATED: 08/26/2020 REQUIRED:

LAST REVISION: SCALE: 1:30

PROJECT NUMBER: DRAWING: -

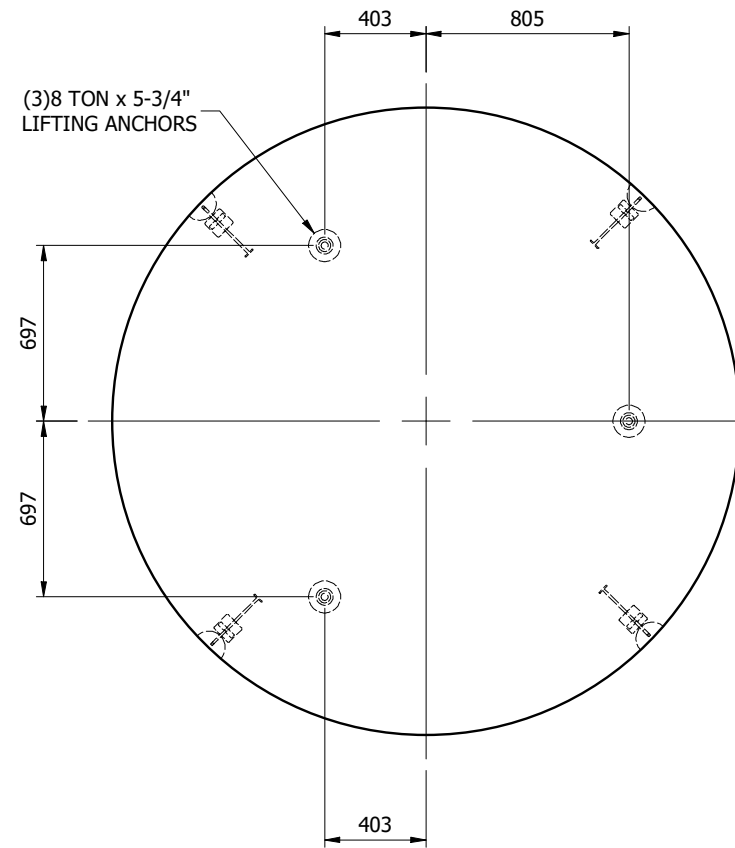
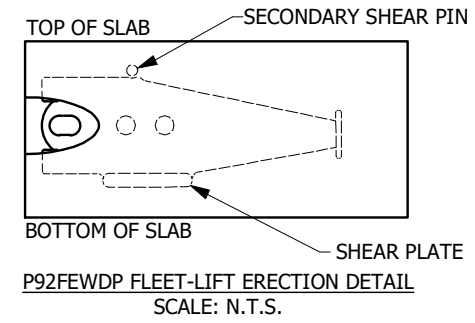
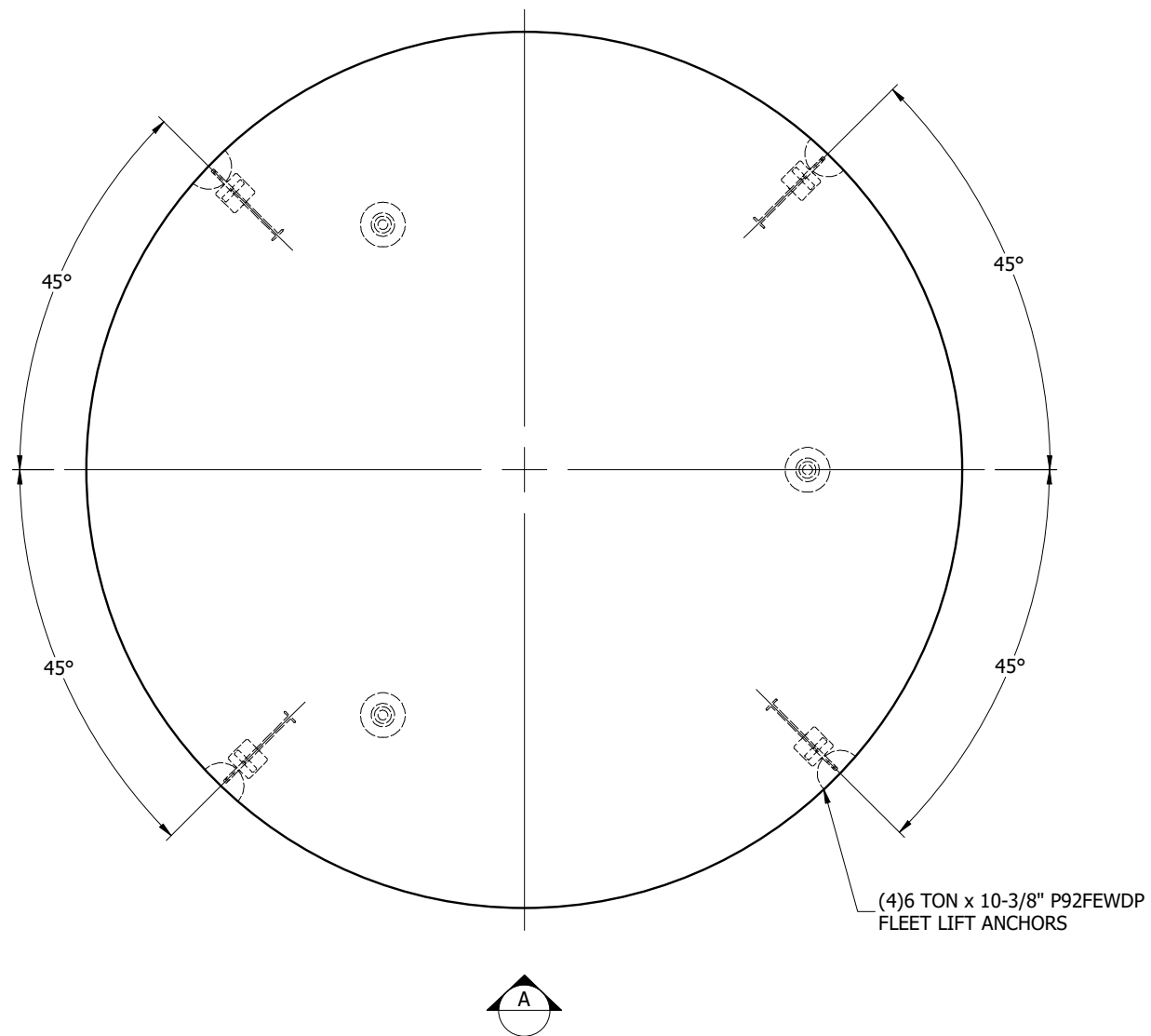

TYP. LIFTING ANCHOR LOCATIONS

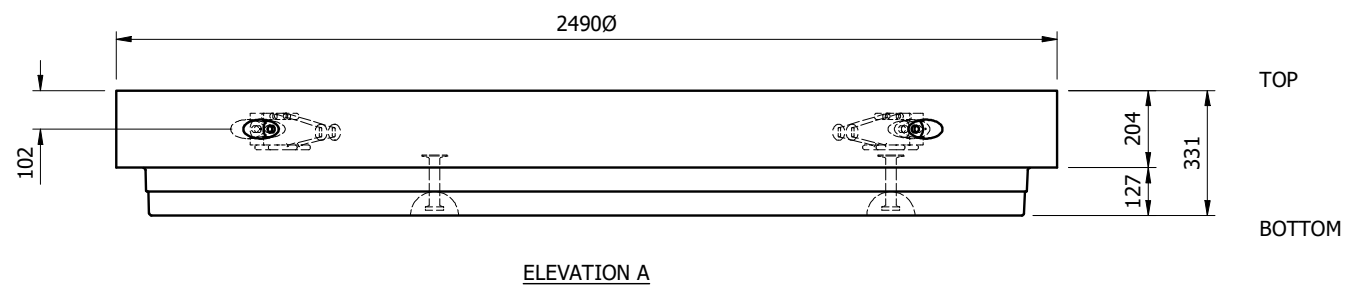

ELEVATION A

NOTES:

- ALL DIMENSIONS ARE IN MILLIMETERS UNLESS OTHERWISE NOTED
- ALL ELEVATIONS ARE IN METERS ABOVE SEA LEVEL

APPROXIMATE WEIGHTS			
PIECE	lb	kg	BURY DEPTH
B1(SLAB)	8,116	3,689	-

# STANDARD TEMPLATE

PROPRIETARY AND CONFIDENTIAL:

THE INFORMATION CONTAINED IN THIS DRAWING IS THE SOLE PROPERTY OF PRECON MANUFACTURING LTD. ANY REPRODUCTION IN PART OR AS A WHOLE WITHOUT THE WRITTEN PERMISSION OF PRECON MANUFACTURING LTD. IS PROHIBITED.



© Precon Manufacturing Ltd. www.precon.ca 1-800-661-8020

CONTRACTOR:  
**PRECON**

PROJECT:  
-

LOCATION:  
-

DESCRIPTION:  
**21380 SLAB BASE**

STRUCTURE NAME:

DRAWN: R.GRANT	CHECKED:
DATE CREATED: 10/25/2021	REQUIRED:
LAST REVISION:	SCALE: 1:20
PROJECT NUMBER: -	DRAWING: <b>D0.7</b>